

Polygon ISO 26623 PSC 40

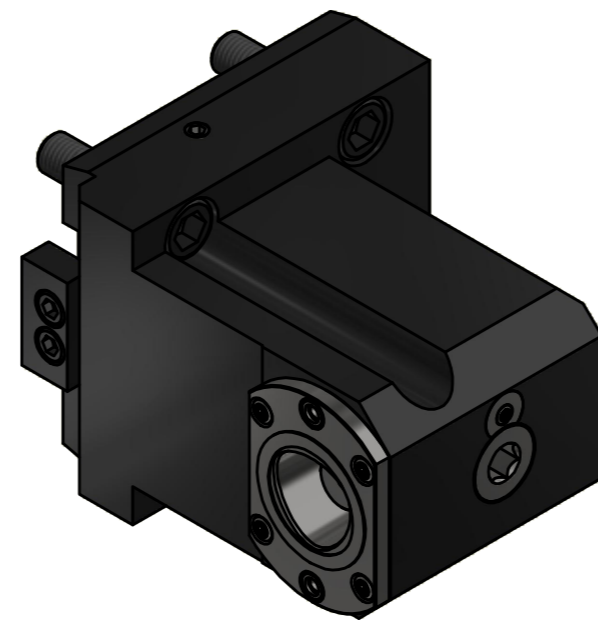
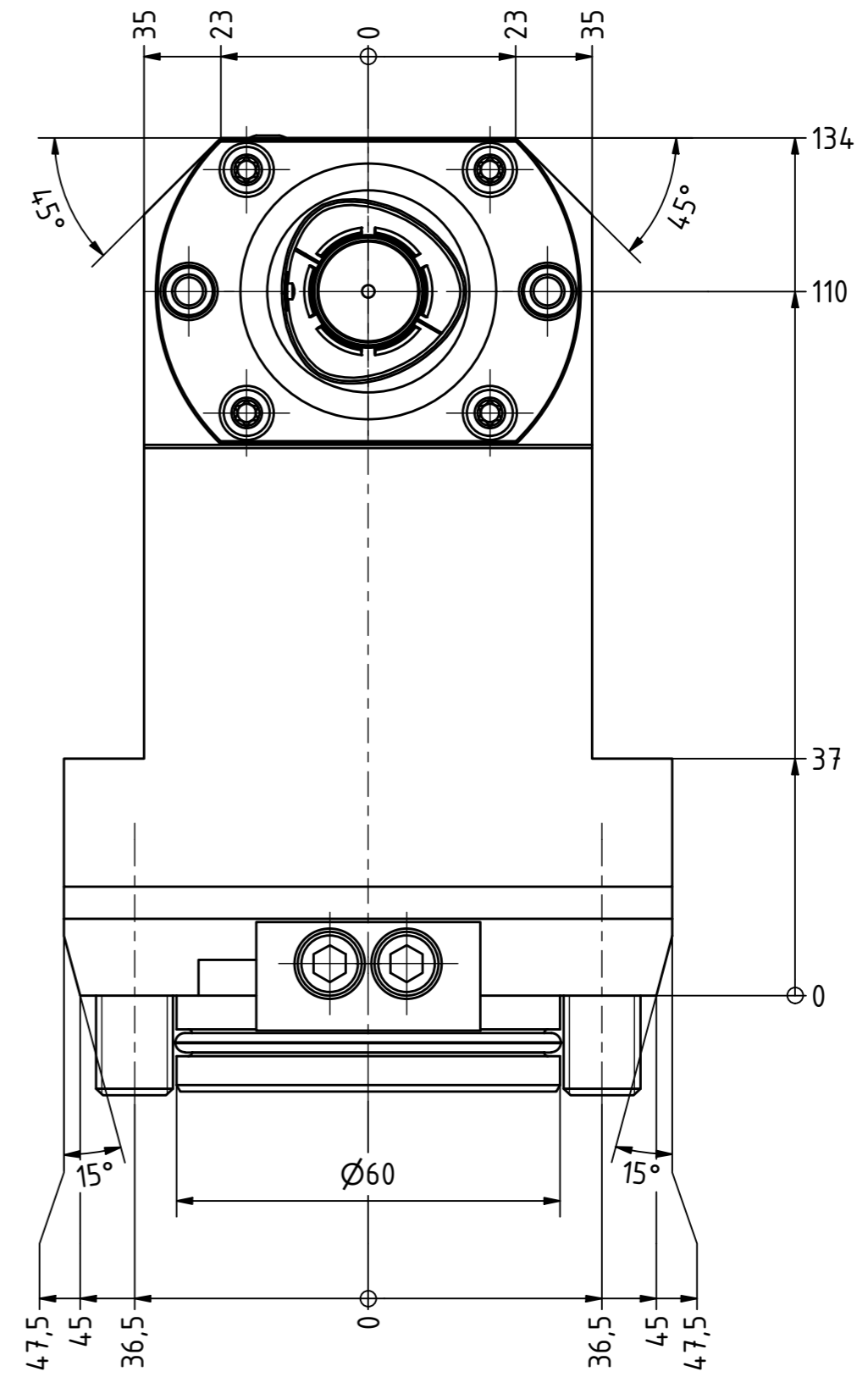
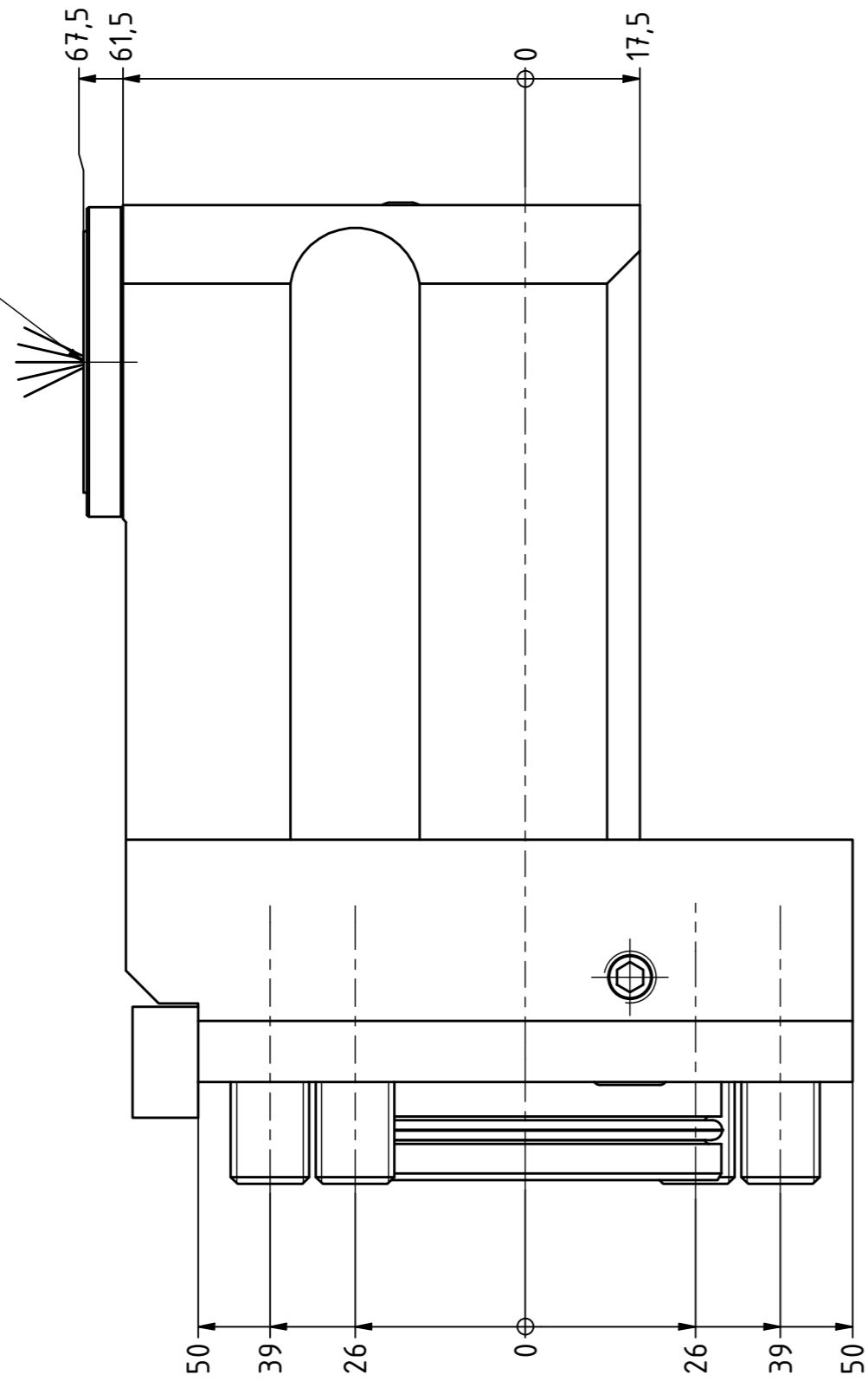

Schaftstück muss für Okuma Multus U3000/U4000 demontiert werden
shank piece must be removed for Okuma Multus U3000/U4000

Copyright **EWS Tool Technologies**
 Weitergabe und Vervielfältigung dieser Unterlage,
 Verwertung und Mitteilung ihres Inhalts nicht
 gestattet, soweit nicht ausdrücklich zugestanden.
 Zuwiderhandlungen verpflichten zu Schadenersatz.

| | | | | | | |
|---|---|---|--|--|---|-----------|
| <p>Benennung - Note</p> <p>MA = 50 Nm max. 80 bar</p> | <p>Technische Daten - technical data</p> <p>Weight = [kg]</p> | <p>Benennung - Title</p> <p>Bohrstangenhalter <i>Boring bar holder</i></p> | <p>EWS Tool Technologies <small>EWS Weigle GmbH & Co. KG Maybachstr. 1 D-73066 Ulm/ingen www.ews-tools.de</small></p> | <p>Technische Änderungen vorbehalten! <i>Subject to technical modifications!</i></p> <p>IDENT: DEWS239442</p> | <p>REV: -/B</p> <p>MNR.</p> <p>173375</p> | <p>QR</p> |
|---|---|---|--|--|---|-----------|