

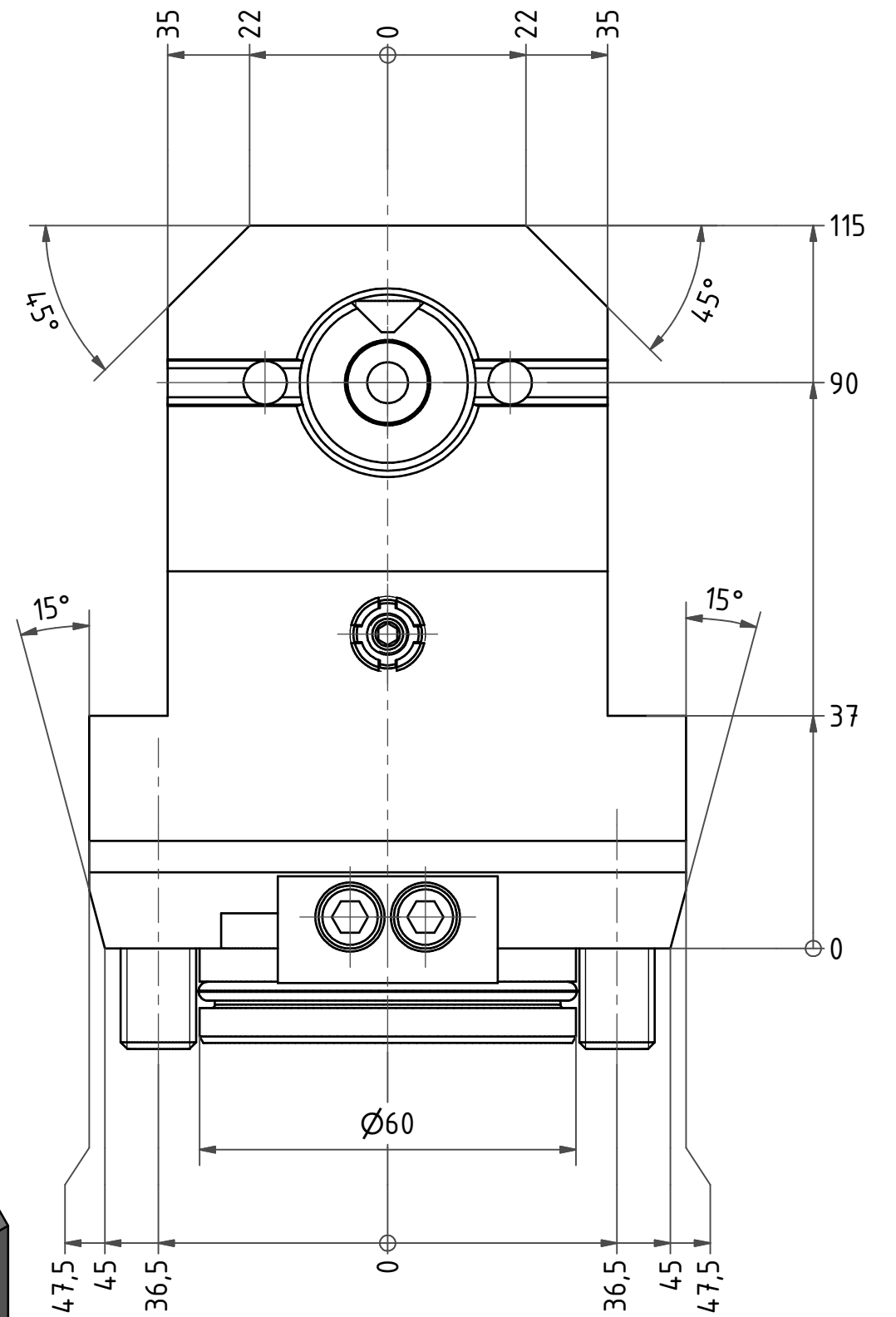

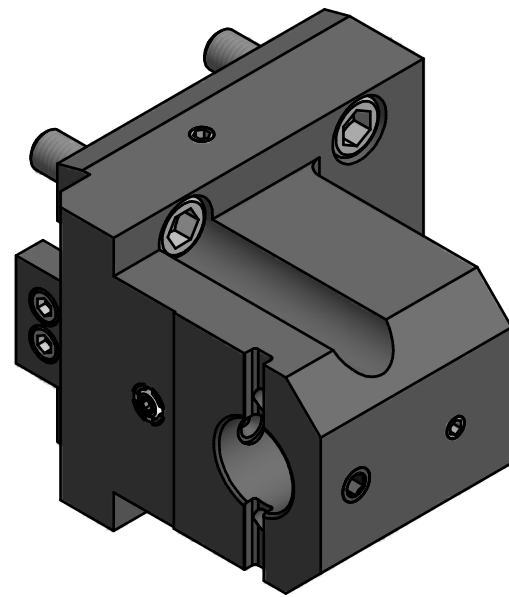

ABS 50  
(Lizenz Komet)

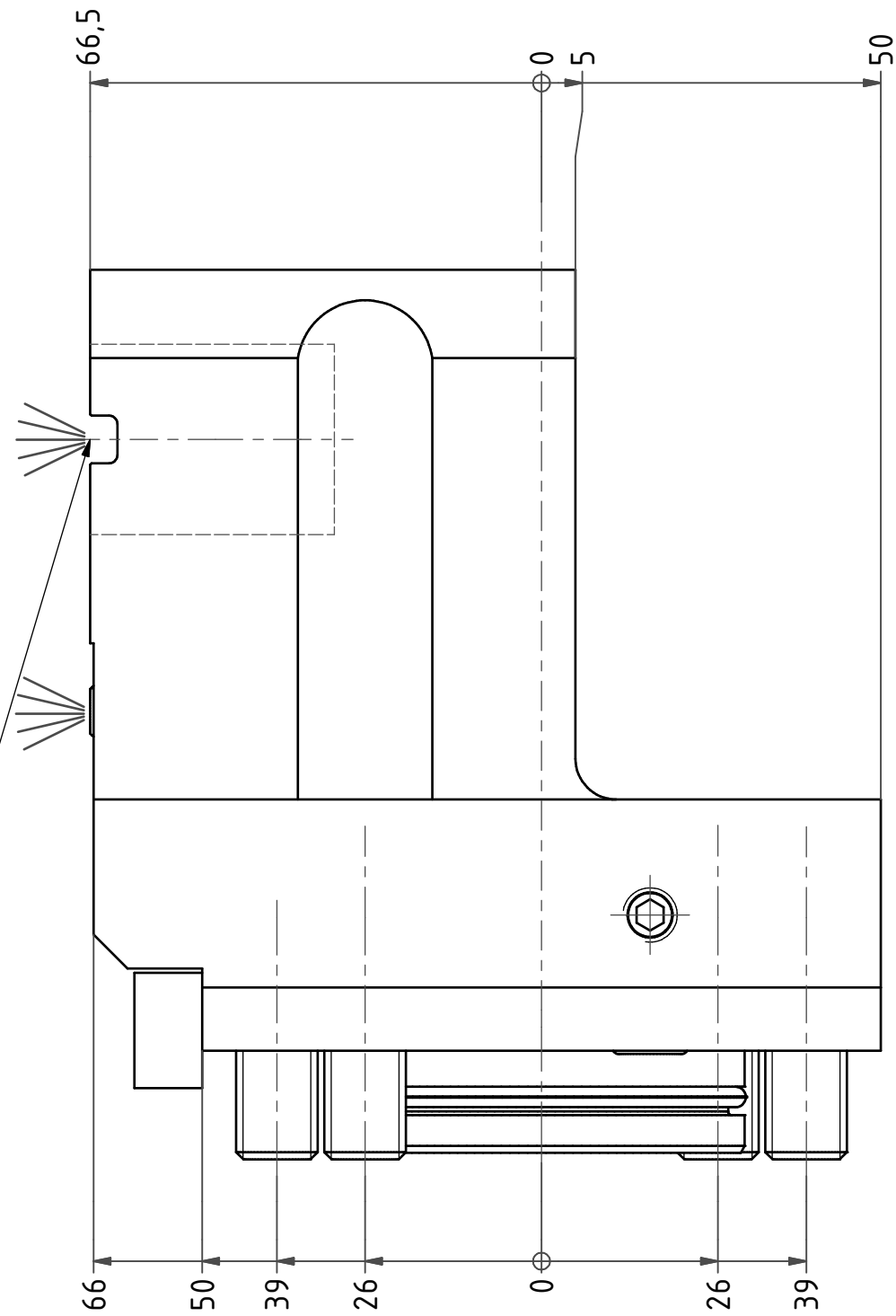

Schaftstück muss für Okuma Multus U3000/U4000 demontiert werden  
shank piece must be removed for Okuma Multus U3000/U4000

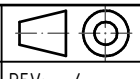
Copyright **EWS Tool Technologies**  
Weitergabe und Vervielfältigung dieser Unterlage,  
Verwertung und Mitteilung ihres Inhalts nicht  
gestattet, soweit nicht ausdrücklich zugestanden.  
Zuwendungen verpflichten zu Schadenersatz.

Bemerkung - Note	Technische Daten - technical data Weight = 5.822 [kg]	Benennung - Title <b>Bohrstangenhalter</b> <i>Boring bar holder</i>	 EWS Weigle GmbH & Co. KG Maybachstr. 1 D-73066 Utingen www.ews-tools.de	Technische Änderungen vorbehalten! Subject to technical modifications! IDENT: D-EWS-207566	 REV: -/- MNR. <b>171092</b>	
Nr. - No.		<b>19.BMTABS50LB2000</b>				