

Spannzange / collet ER25 DIN6499
 Spannbereich / clamping range: 1,0 - 16,0

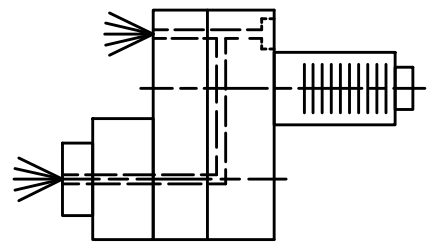

Innen- und Aussenkuehlung / Inside and outside coolant supply
 Kein Trockenlauf / No dry run
 Kuehlmittelfiltrierung <math>< 50\mu</math> / coolant filtration <math>< 50\mu</math>

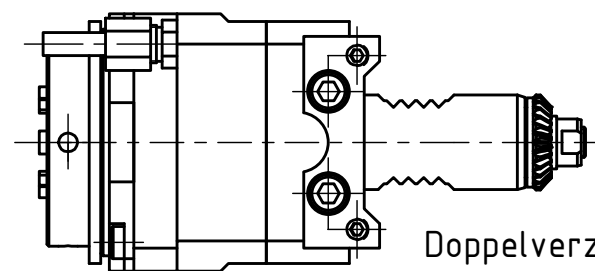

Doppelverzahnung Lizenz Traub
 double tooth system licence Traub

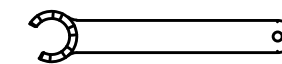
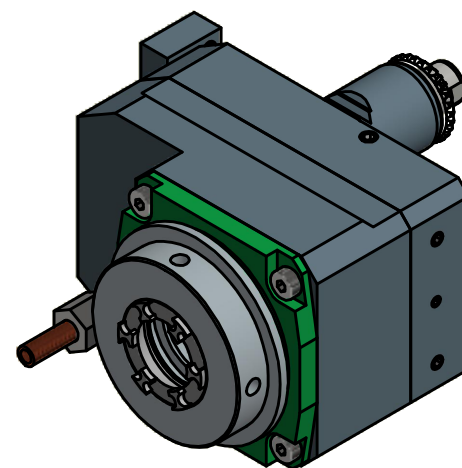

Spannzangenschlüssel für
 innenliegende Mutter
 Clamping wrench for
 internal collet
 225AX

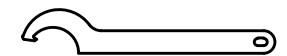

Hakenschlüssel
 mit Nase
 Hook wrench with
 nose end
 DIN1810 A 58x62

Copyright **EWS Tool Technologies**
 Weitergabe und Vervielfaeltigung dieser Unterlage,
 Verwertung und Mitteilung ihres Inhalts nicht
 gestattet, soweit nicht ausdrecklich zugestanden.
 Zuwiderhandlungen verpflichten zu Schadenersatz.

Bemerkung - Note
 Nicht ohne Kuehlmittel betreiben!
 Not for use without coolant-fluid!

Technische Daten - technical data	
Weight	= 3.048 [kg]
Torque max. (M1/M2)	= 25 / 25 [Nm]
Speed max. (n1/n2)	= 8000 / 8000 [1/min]
Gear ratio (i)=n1:n2	= 1:1
Pressure (pmax)	= 70 [bar]

Benennung - Title
Axial Bohr u. Fräskopf achsversetzt
Ax. drill. and mill. head offset

EWS Tool Technologies
 EWS Weigele GmbH & Co. KG
 Maybachstr. 1
 D-73066 Uehingen
 www.ews-tools.de

Nr. - No.
50.2525TNC30RLIKIM

Technische Aenderungen vorbehalten!
 Subject to technical modifications!
 IDENT: D-EWS-142364
 REV: -/A
 MNR.
170158

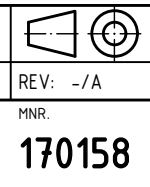

QR