

Spannzange / Collet ER16 DIN6499
 Spannbereich / Clamping range: 1,0 - 10,0

Gewindebohrzange / Tapping Collet
 ET-1-16 M1-M6

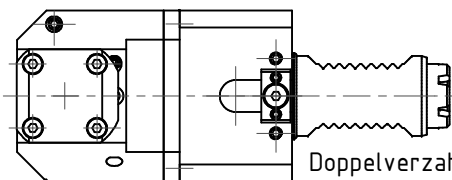

Doppelverzahnung Lizenz Traub
 double tooth system licence Traub

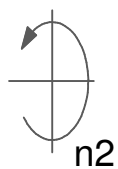
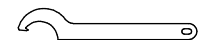
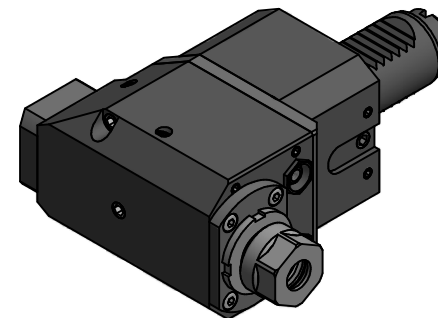
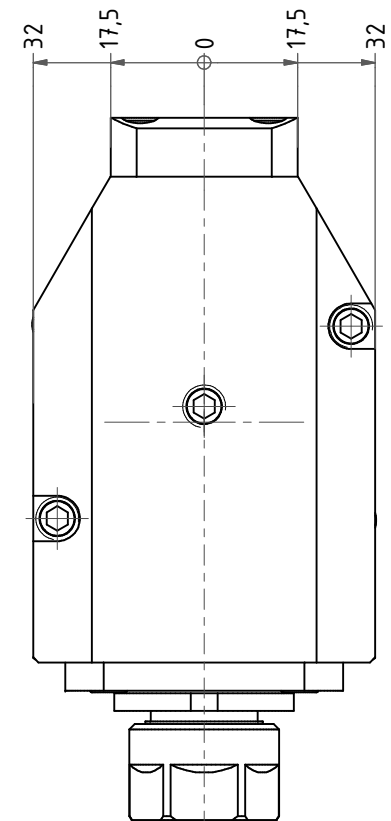

Hakenschlüssel
 mit Nase
 Hook wrench with
 nose end
 DIN1810 A 34x36

Copyright **EWS Tool Technologies**
 Weitergabe und Vervielfältigung dieser Unterlage,
 Verwertung und Mitteilung ihres Inhalts nicht
 gestattet, soweit nicht ausdrücklich zugestanden.
 Zuwiderhandlungen verpflichten zu Schadenersatz.

Bemerkung - Note

Technische Daten - technical data

Weight = 3.724 [kg]
 Torque max. (M1/M2) = 15 / 5 [Nm]
 Speed max. (n1/n2) = 6000 / 18000 [1/min]
 Gear ratio (i)=n1:n2 = 1:3

Benennung - Title

Radial Bohr und Fräskopf
Radial drilling and milling head



Nr. - No.

60.3016TOEMRLI13X85

EWS Weigle GmbH & Co. KG
 Maybachstr. 1
 D-73066 Uhingen
 www.ews-tools.de

Technische Änderungen vorbehalten!
 Subject to technical modifications!

IDENT: DEWS000188



REV: -/B

MNR.

173075

