

Spannzange / collet ER32 DIN6499  
Spannbereich / clamping range: 2,0 - 20,0

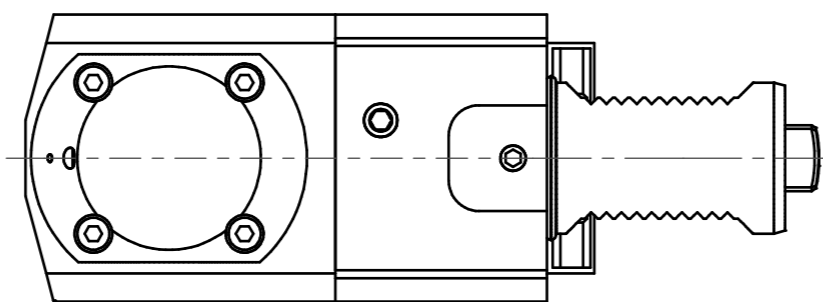

Doppelverzahnung Lizenz Traub  
double tooth system licence Traub

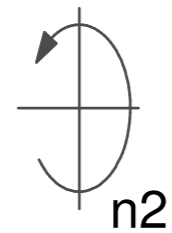
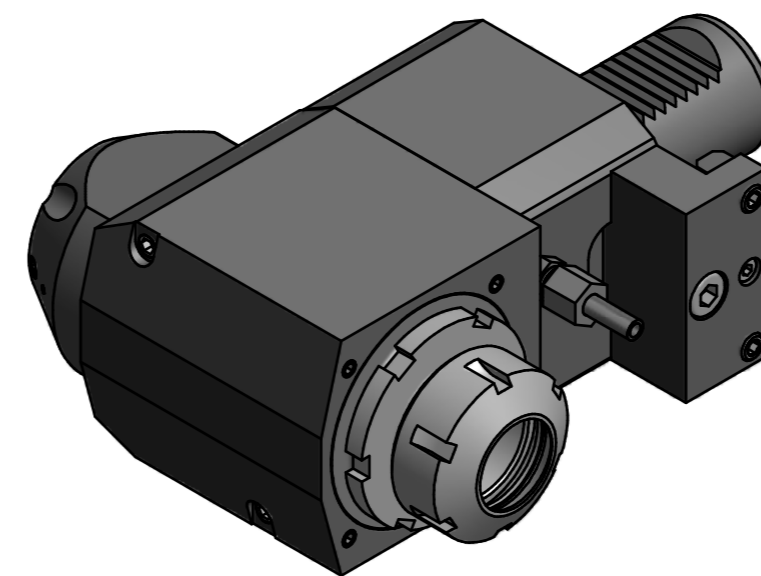

Spannzangenschlüssel  
Clamping wrench  
232

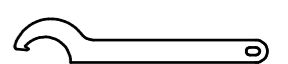

Hakenschlüssel  
mit Nase  
Hook wrench with  
nose end  
DIN1810 A 58x62

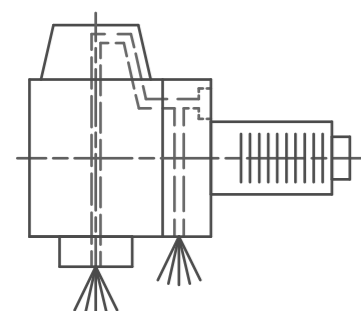

Innen- und Aussenkuehlung / Inside and outside coolant supply  
Kein Trockenlauf / No dry run  
Kuehlmittefiltrierung <math>50\mu</math> / coolant filtration <math>50\mu</math>

Copyright **EWS Tool Technologies**  
Weitergabe und Vervielfaeltigung dieser Unterlage,  
Verwertung und Mitteilung ihres Inhalts nicht  
gestattet, soweit nicht ausdrecklich zugestanden.  
Zuwaenderhandlungen verpflichten zu Schadenersatz.

Bemerkung - Note Nicht ohne Kuehlmitte betreiben! Not for use without coolant-fluid!		Technische Daten - Technical data $M1 / M2 = 50 / 25 \text{ Nm}$ $n1 / n2 = 5000 / 10000 \text{ 1/min}$ $i (N1:N2) = 1:2$ $p_{max} = 70 \text{ bar}$		Benennung - Title <b>Radial Bohr und Fräskopf</b> <b>Radial drilling and milling head</b>		name F.Miltschuh date 11.03.2014		Technische Aenderungen vorbehalten! Subject to technical modifications!			
						Nr. <b>60.40321809RLIK11AP50X100</b>		MNR: 172931 IDENT: D-EWS-153033 -		Blatt - page 1 (1)	