

Spannzange / collet ER25 DIN6499  
Spannbereich / clamping range: 1,0 - 16,0

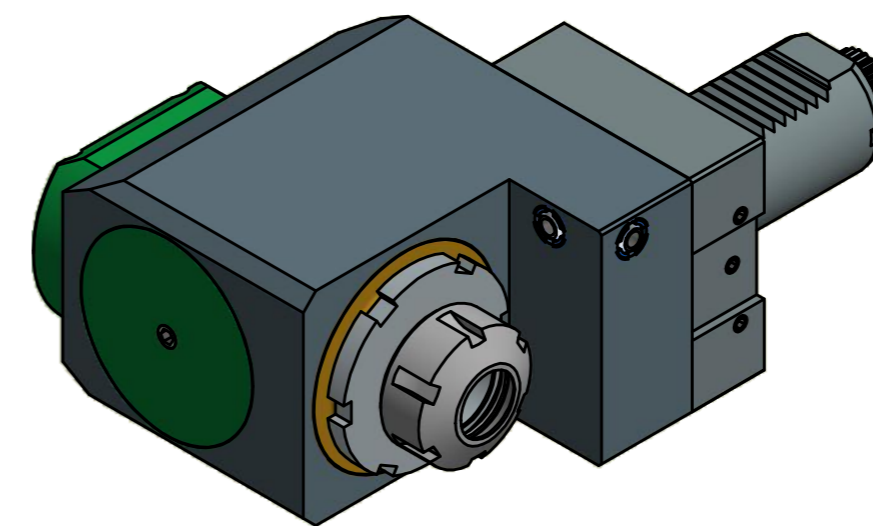

Gewindebohrzange / tapping collet  
ET-1-25 M3-M10

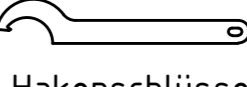

  
Hakenschlüssel  
mit Nase  
Hook wrench with  
nose end  
DIN1810 A 58x62

  
Spannzangenschlüssel  
Clamping wrench  
225

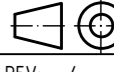
Copyright **EWS Tool Technologies**  
Weitergabe und Vervielfältigung dieser Unterlage,  
Verwertung und Mitteilung ihres Inhalts nicht  
gestattet, soweit nicht ausdrücklich zugestanden.  
Zuwendungen verpflichten zu Schadenersatz.

Bemerkung - Note	Technische Daten - technical data Weight = 7.259 [kg] Torque max. (M1/M2) = 45 / 15 [Nm] Speed max. (n1/n2) = 6000 / 18000 [1/min] Gear ratio (i)=n1:n2 = 1:3	Benennung - Title Radial Bohr und Fräskopf, zurückges Radial drill. and mill. head offset	 <b>EWS</b> Weigle GmbH & Co. KG Maybachstr. 1 D-73066 Uhingen www.ews-tools.de	Technische Änderungen vorbehalten! Subject to technical modifications! IDENT: D-EWS-141607	 MNR REV: -/- 170000	
------------------	---	---	---	--	---	---