

Spannzange / collet ER40 DIN6499
 Spannbereich / clamping range: 3,0 - 26,0

Gewindebohrzange / tapping collet
 ET-1-40 M6-M16

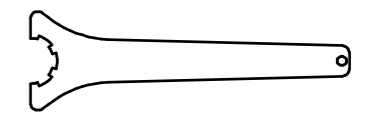

Spannzangenschlüssel
 Clamping wrench
 240

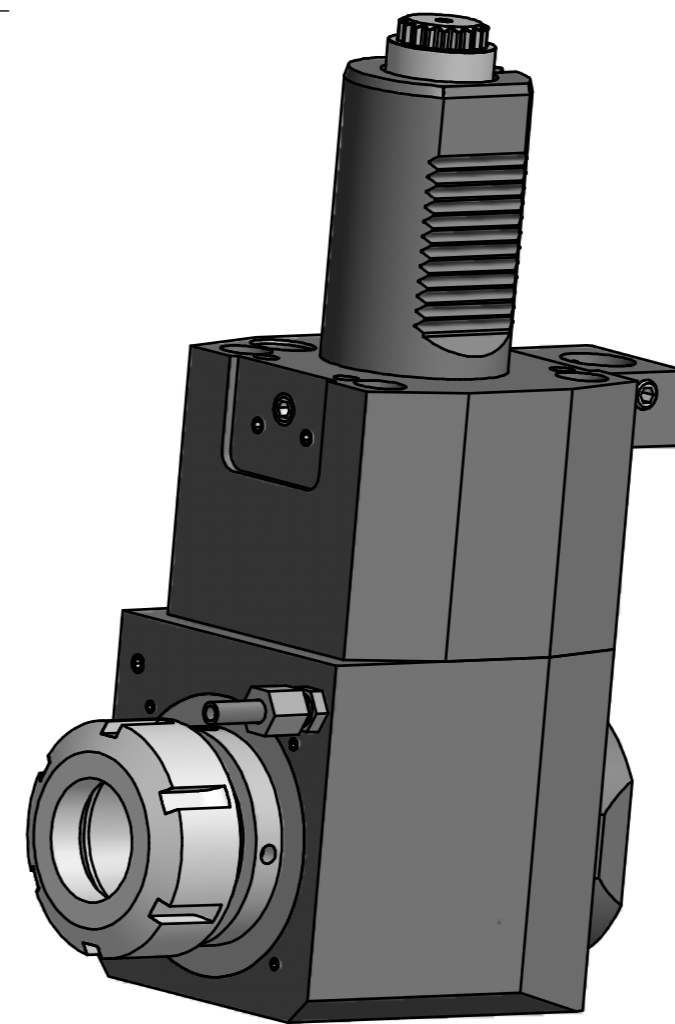
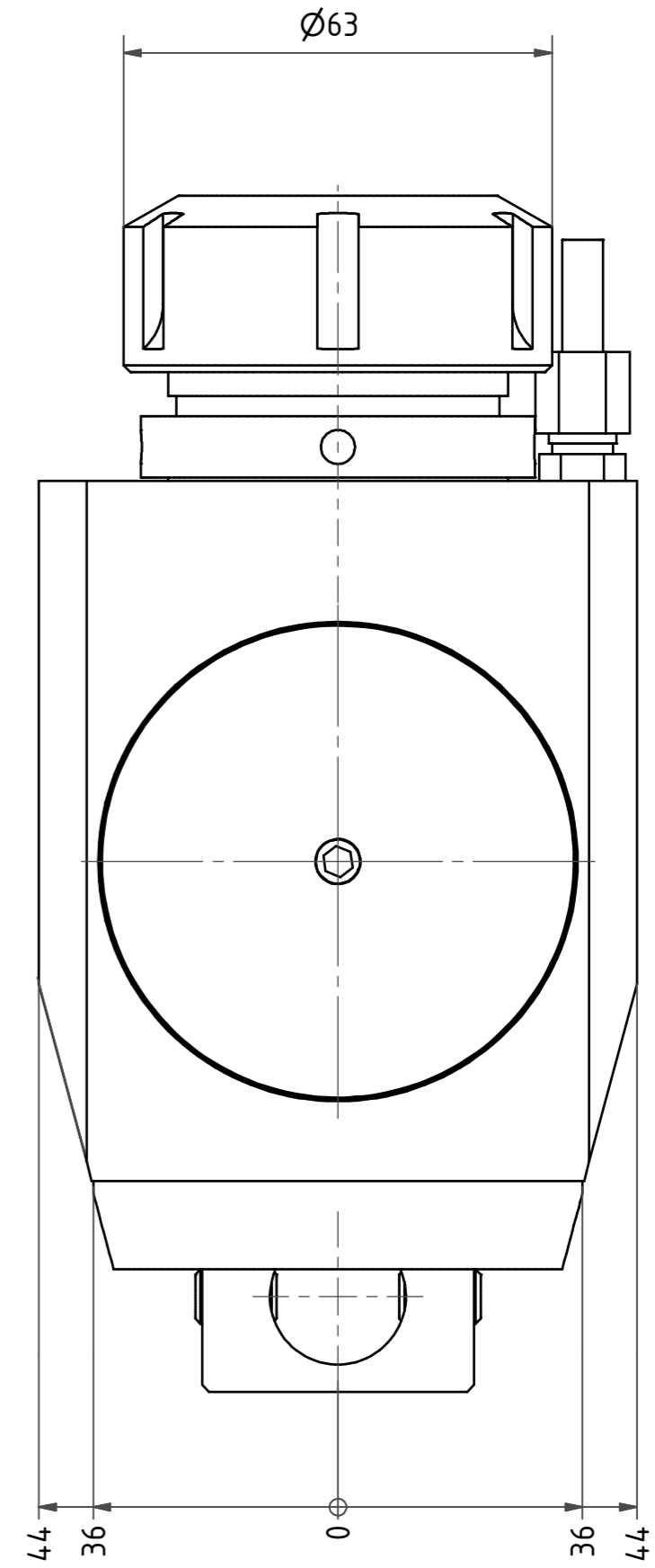
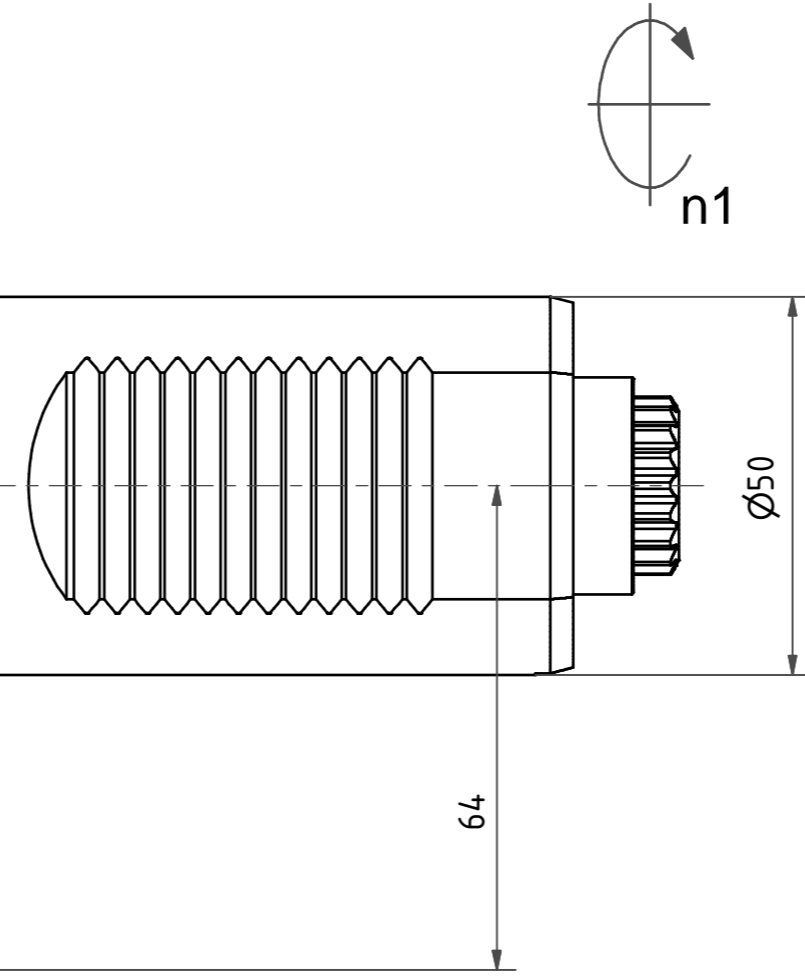
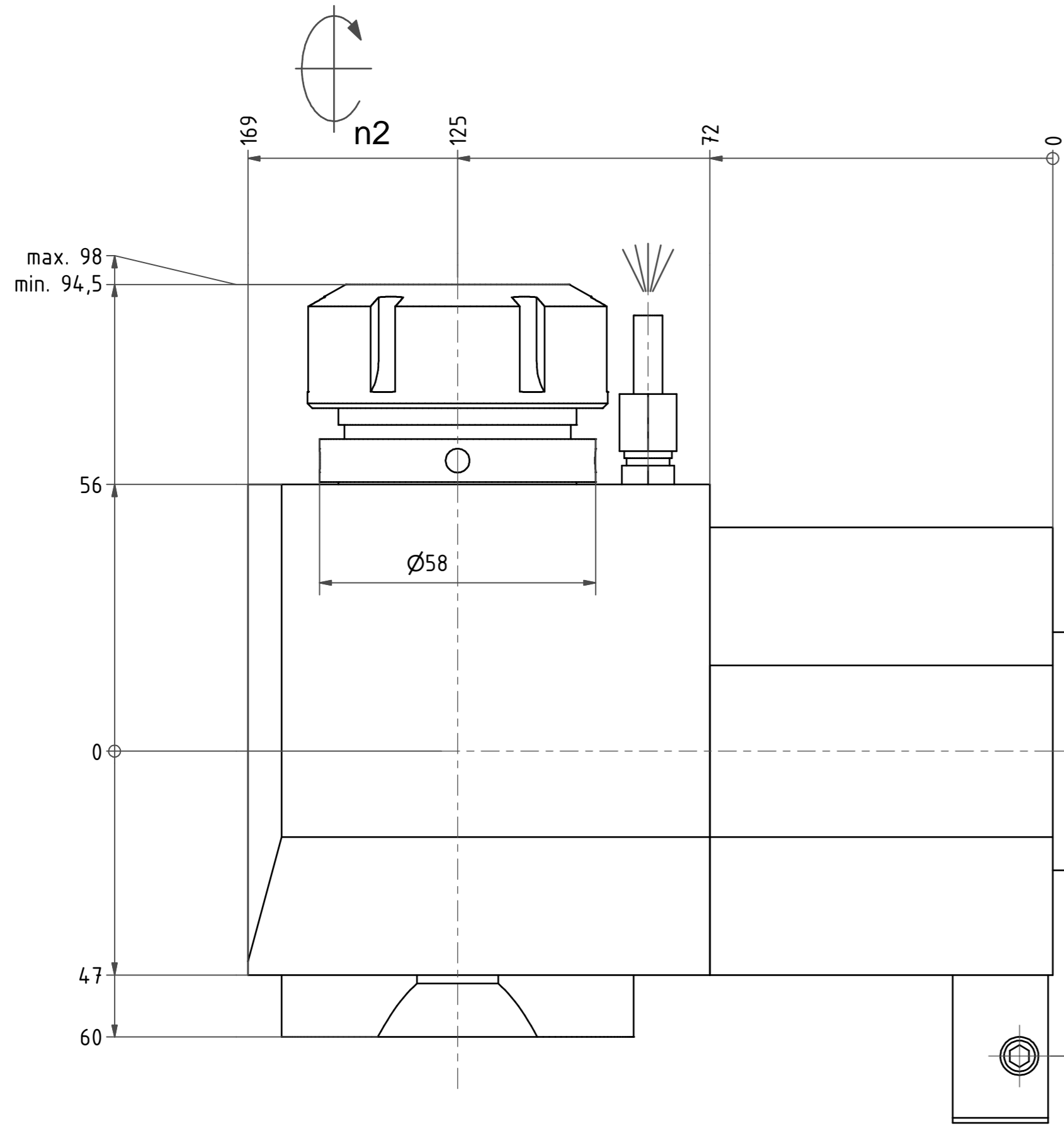
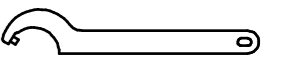

Hakenschlüssel
 mit Zapfen
 Hook wrench
 with fixed pin
 DIN1810 B 58x62

Copyright **EWS Tool Technologies**
 Weitergabe und Vervielfältigung dieser Unterlage,
 Verwertung und Mitteilung ihres Inhalts nicht
 gestattet, soweit nicht ausdrücklich zugestanden.
 Zuwiderhandlungen verpflichten zu Schadenersatz.

Bemerkung - Note	Technische Daten - technical data		Benennung - Title	name	date	Technische Änderungen vorbehalten! Subject to technical modifications!
	M ₁ / M ₂ = 100 / 100 Nm	n ₁ / n ₂ = 4000 / 4000 1/min				
	i (N ₁ :N ₂) = 1:1	Radial Bohr und Fräskopf Radial drilling and milling head		EWS Weigete GmbH & Co. KG Maybachstr. 1 D-73066 Ulm/lingen Tel. +49(0)7161/93040-10	Nr. 60.5040L5480LGLX125	DIN A2