

Spannzange / collet ER20 DIN6499
Spannbereich / clamping range: 1,0 - 13,0

Gewindebohrzange / tapping collet
ET-1-20 M2-M6

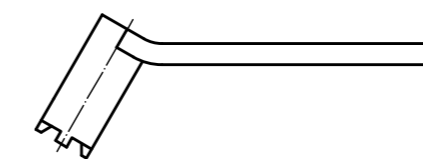

Schlüssel für Ausrichtung
im Lieferumfang enthalten.
Wrench for adjustment
included in delivery
AZS-LT2000

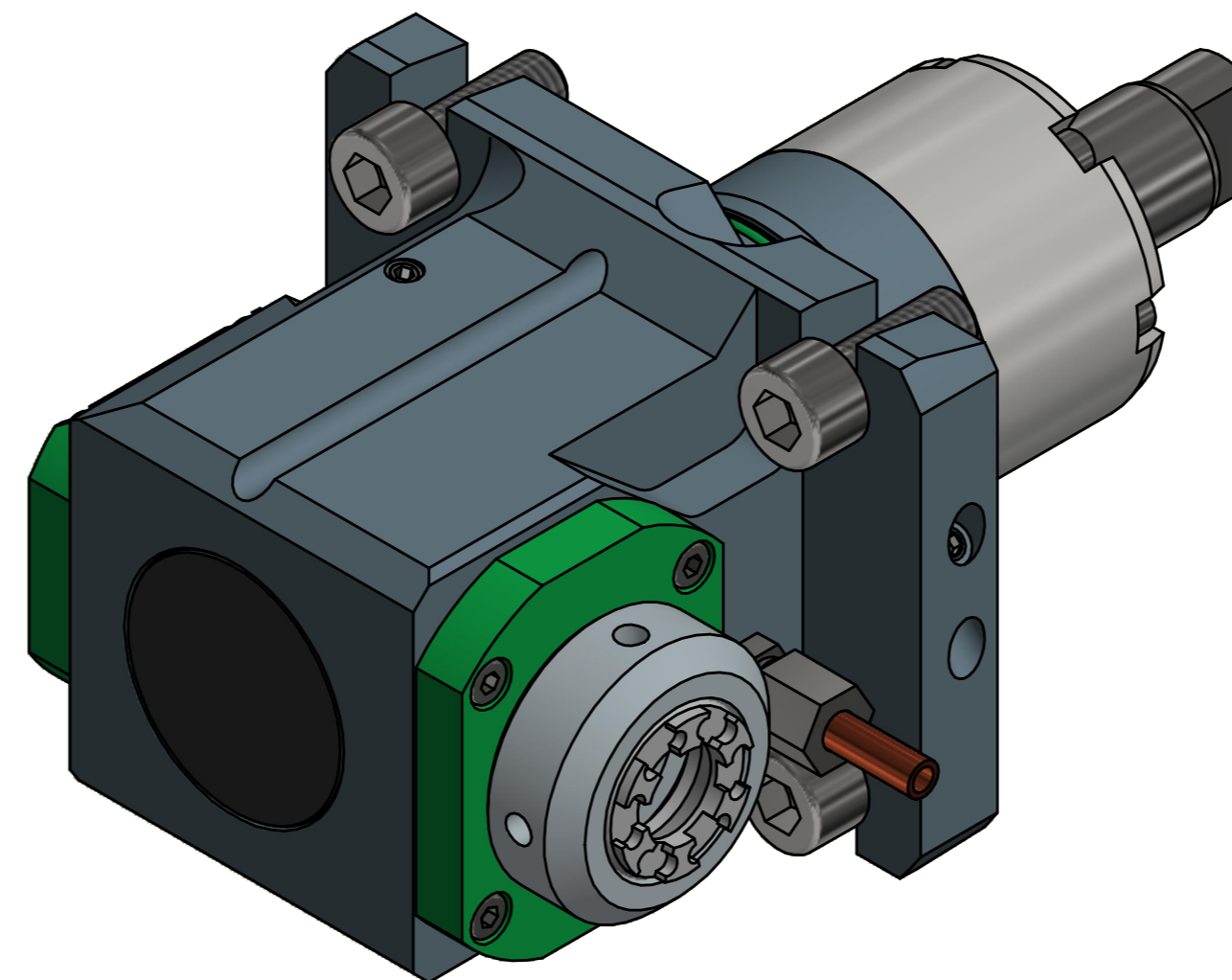
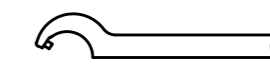

Hakenschlüssel
mit Zapfen
Hook wrench
with fixed pin
DIN1810 B 45x50

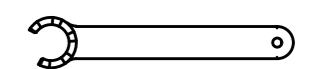

Spannzangenschlüssel für
innenliegende Mutter
Clamping wrench for
internal collet
220AX

Copyright **EWS Tool Technologies**
Weitergabe und Vervielfältigung dieser Unterlage,
Verwertung und Mitteilung ihres Inhalts nicht
gestattet, soweit nicht ausdrücklich zugestanden.
Zuwerhandlungen verpflichten zu Schadenersatz.

Bemerkung - Note

Technische Daten - technical data
Weight = 4,599 [kg]
Torque max. (M1/M2) = 24 / 12 [Nm]
Speed max. (n1/n2) = 6000 / 12000 [1/min]
Gear ratio (i)=n1:n2 = 1:2

Benennung - Title

Radial Bohr und Fräskopf
Radial drilling and milling head



Technische Änderungen vorbehalten!
Subject to technical modifications!
IDENT: DEWS054076

Nr. - No.
60.55.420LT2000V1611M

REV: -/B
MNR.
170734

