

* Bemerkung: für die SPINNER TC77SMCY/TC110SMCY Maschine (mit Gegenspindel) sind 130mm ausreichend!
 Note: for the SPINNER TC77SMCY/TC110SMCY machine (with opposed spindle) are 130mm sufficient!

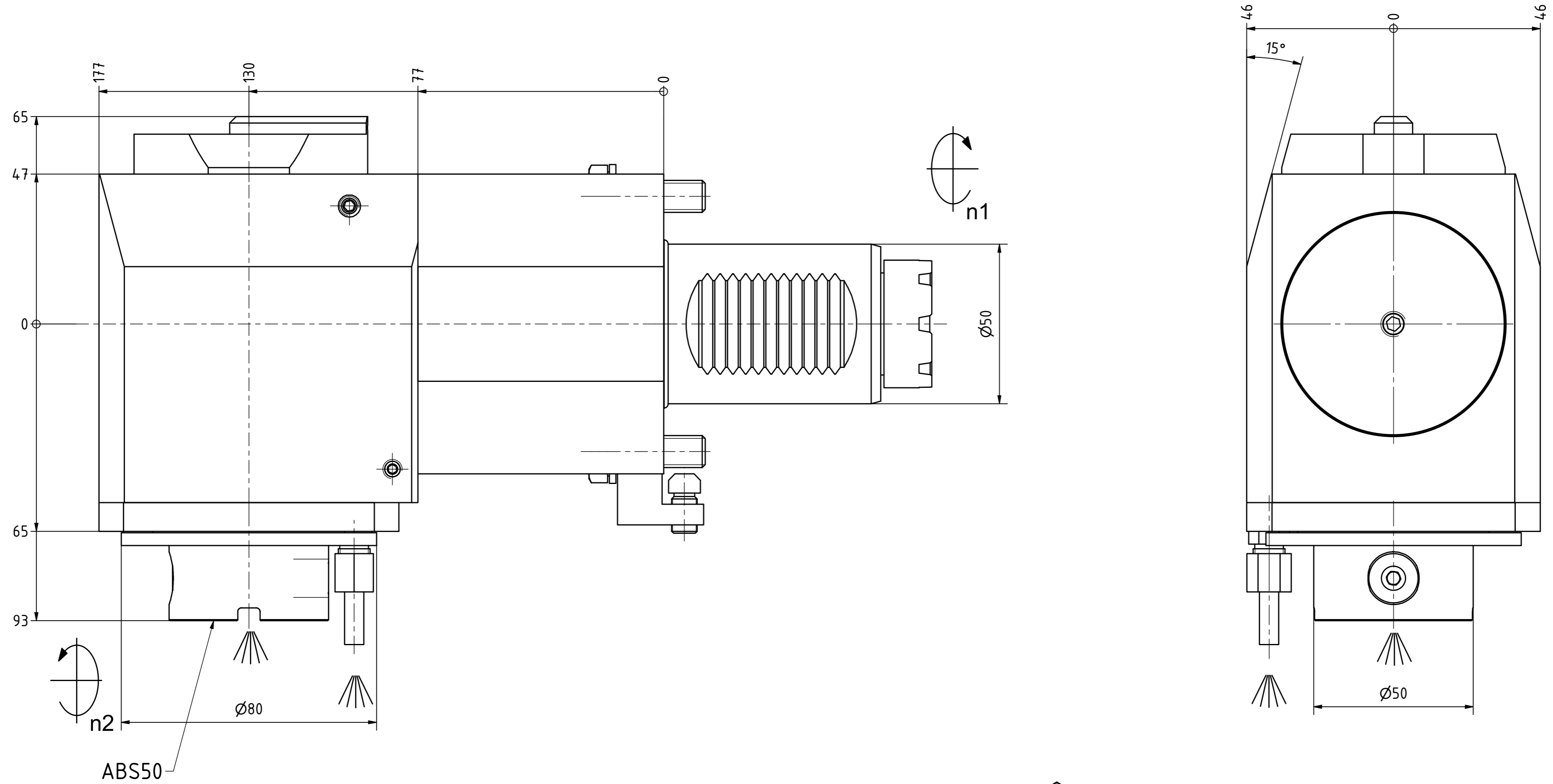

ABS50

(1:2)

Doppelverzahnung Lizenz Traub
 double tooth system licence Traub

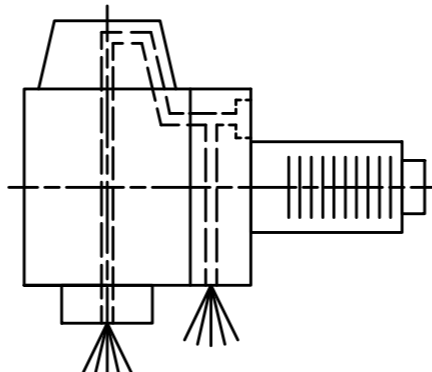
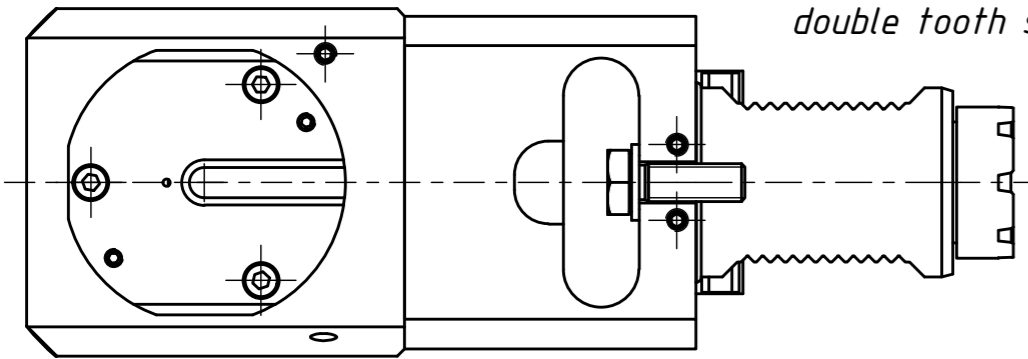

Innen- und Aussenkuehlung / Inside and outside coolant supply
 Kuehlmittelfiltrierung-50µ / coolant filtration-50µ

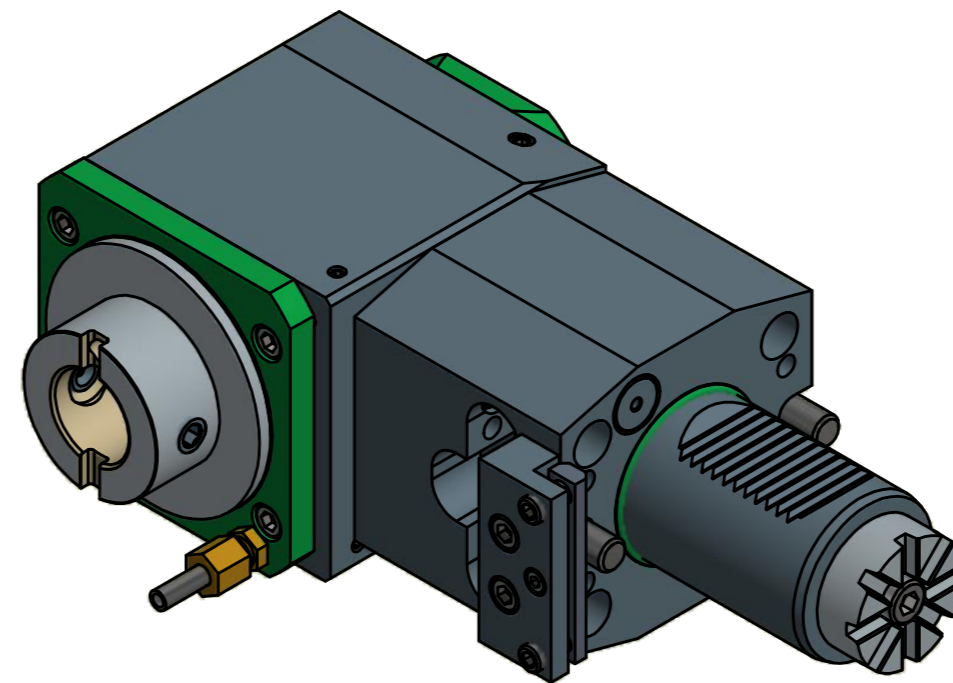

Copyright **EWS Tool Technologies**
 Weitergabe und Vervielfaeltigung dieser Unterlage,
 Verwertung und Mitteilung ihres Inhalts nicht
 gestattet, soweit nicht ausdrecklich zugestanden.
 Zuwiderhandlungen verpflichten zu Schadenersatz.

<p>Bemerkung - Note Für Trockenlauf geeignet! Use without coolant fluid allowed! mit Kegelrollenlager with taper roller bearing(s)</p>	<p>Technische Daten - technical data Weight = 11,682 [kg] Torque max. (M1/M2) = 100 / 100 [Nm] Speed max. (n1/n2) = 4,000 / 4,000 [1/min] Gear ratio (i)=n1:n2 = 1:1 Pressure (pmax) = 70 [bar]</p>	<p>Benennung - Title Radial Bohr und Fräskopf Radial drilling and milling head</p>	<p>EWS Tool Technologies EWS Weigle GmbH & Co. KG Maybachstr. 1 D-73066 Uhlingen www.ews-tool.de</p>	<p>Technische Aenderungen vorbehalten! Subject to technical modifications! IDENT: D-EWS-050384</p>	<p>REV: -/- MNR. 136655</p>
--	--	--	--	--	---

