

Spannzange / collet ER25 DIN6499
 Spannbereich / clamping range: 1,0 - 16,0

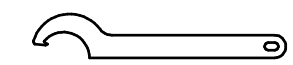

Hakenschlüssel
 mit Nase
 Hook wrench with
 nose end
 DIN1810 A 45x50

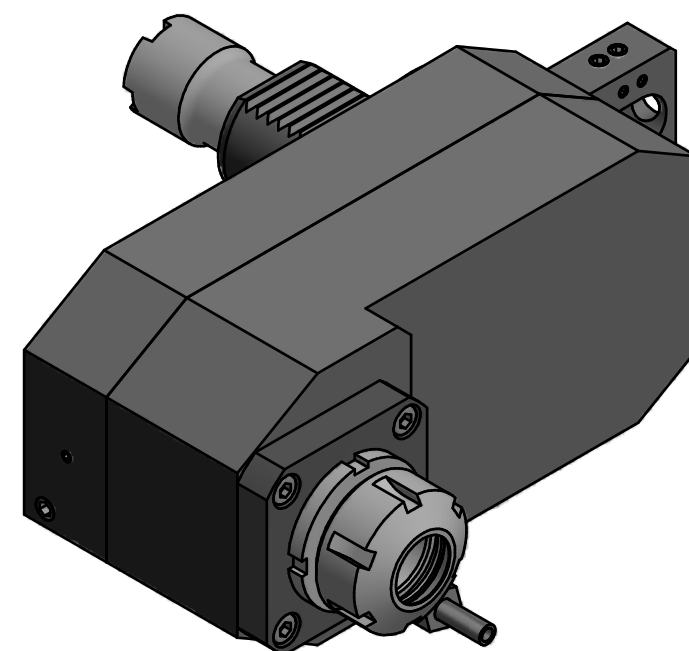
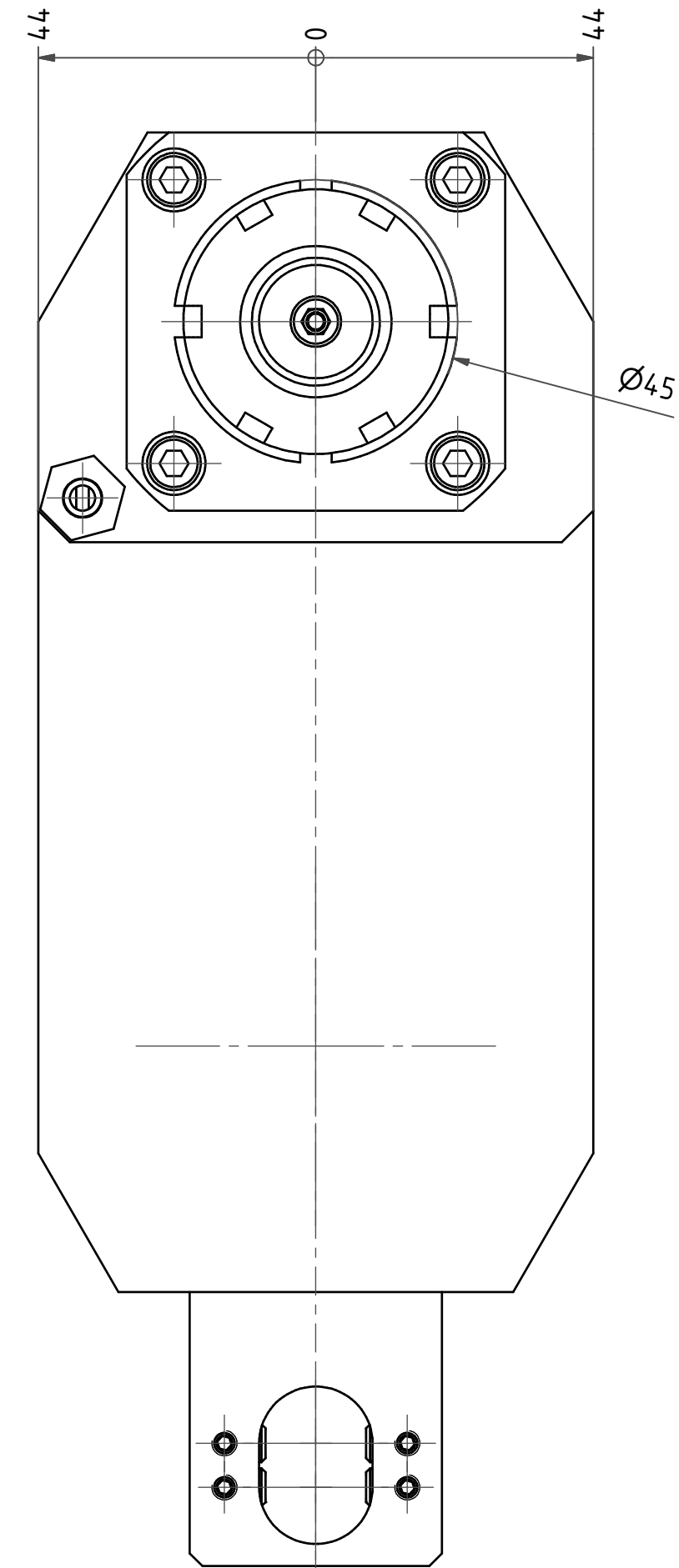
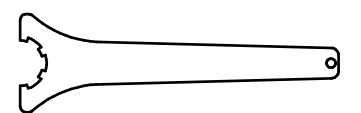

Spannzangenschlüssel
 Clamping wrench
 225

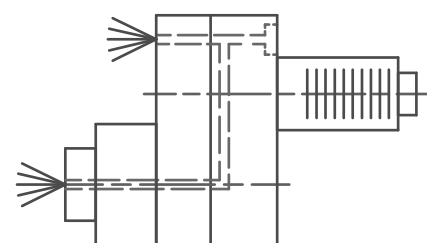

Innen- und Aussenkuehlung / Inside and outside coolant supply
 Kein Trockenlauf / No dry run
 Kuehlmittelfiltrierung=50µ / coolant filtration=50µ

Bemerkung - Note
 Nicht ohne Kuehlmittel betreiben!
 Not for use without coolant-fluid!

Technische Daten - technical data
 Weight = 9,042 [kg]
 Torque max. (M1/M2) = 50 / 25 [Nm]
 Speed max. (n1/n2) = 6000 / 12000 [1/min]
 Gear ratio (i)=n1:n2 = 1:2
 Pressure (pmax) = 70 [bar]

Benennung - Title
Axial Bohr u. Fräskopf achsversetzt
 Ax. drill. and mill. head offset



Nr. - No.
50.4025LB300MWLIK1

Technische Aenderungen vorbehalten!
 Subject to technical modifications!
 IDENT: 0-EWS-146962

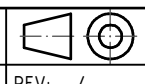

REV: -/-
 MNR.
170727

Copyright **EWS Tool Technologies**
 Weitergabe und Vervielfaeltigung dieser Unterlage,
 Verwertung und Mitteilung ihres Inhalts nicht
 gestattet, soweit nicht ausdrecklich zugestanden.
 Zuwiderhandlungen verpflichten zu Schadenersatz.

