

Spannzange / collet ER32 DIN64.99  
Spannbereich / clamping range: 2,0 - 20,0

Gewindebohrzange / tapping collet  
ET-1-32 M5-M12

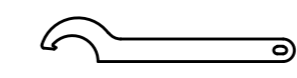

Hakenschlüssel  
mit Nase  
Hook wrench with  
nose end  
DIN1810 A 68x75

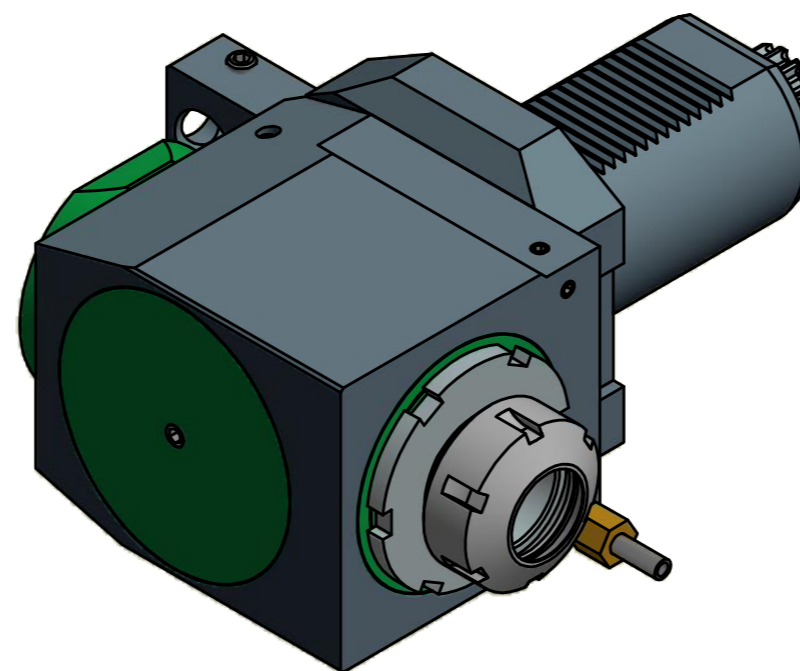

Spannzangenschlüssel  
Clamping wrench  
232

Copyright **EWS Tool Technologies**  
Weitergabe und Vervielfältigung dieser Unterlage,  
Verwertung und Mitteilung ihres Inhalts nicht  
gestattet, soweit nicht ausdrücklich zugestanden.  
Zuwerhandlungen verpflichten zu Schadenersatz.

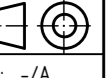
Bemerkung - Note	Technische Daten - technical data Weight = 9.413 [kg] Torque max. (M1/M2) = 160 / 80 [Nm] Speed max. (n1/n2) = 3000 / 6000 [1/min] Gear ratio (i)=n1:n2 = 1:2	Benennung - Title <b>Radial Bohr und Fräskopf</b> <i>Radial drilling and milling head</i>	 EWS Weigle GmbH & Co. KG Maybachstr. 1 D-73066 Ulm/ingen www.ews-tools.de	Technische Änderungen vorbehalten! Subject to technical modifications! IDENT: DEWS035952 Nr. - No. 60.60325482R11 MNR. 136559	 REV: -/A <b>QR</b>
------------------	---	---	--	---	---