

Spannzange / collet ER32 DIN6499  
 Spannbereich / clamping range: 2,0 - 20,0

Gewindebohrzange / tapping collet  
 ET-1-32 M5-M12

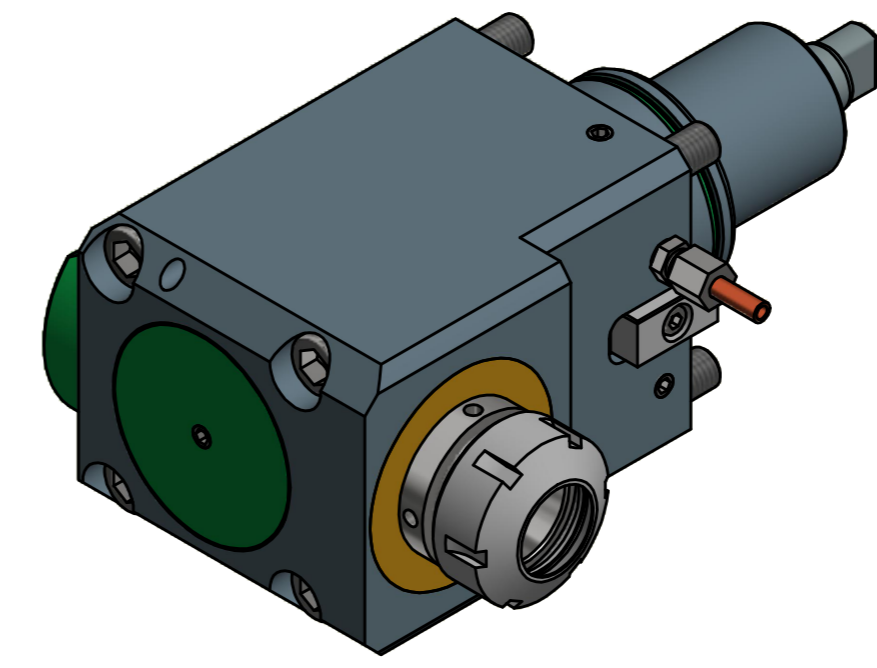



Hakenschlüssel  
 mit Zapfen  
 Hook wrench  
 with fixed pin  
 DIN1810 B 45x50



Spannzangenschlüssel  
 Clamping wrench  
 232

Copyright **EWS Tool Technologies**  
 Weitergabe und Vervielfältigung dieser Unterlage,  
 Verwertung und Mitteilung ihres Inhalts nicht  
 gestattet, soweit nicht ausdrücklich zugestanden.  
 Zuwiderhandlungen verpflichten zu Schadenersatz.

Bemerkung - Note	Technische Daten - technical data Weight = 10.149 [kg] Torque max. (M1/M2) = 50 / 50 [Nm] Speed max. (n1/n2) = 6000 / 6000 [1/min] Gear ratio (i)=n1:n2 = 1:1	Benennung - Title <b>Radial Bohr und Fräskopf</b> <b>Radial drilling and milling head</b>	 EWS Weigle GmbH & Co. KG Maybachstr. 1 D-73066 Uhlingen www.ews-tool.de	Technische Änderungen vorbehalten! Subject to technical modifications! IDENT: DEWS119414 Nr. - No. 60.65321809N4GLX100	MNR. REV: -/B 171480	
------------------	---	---	--	---	-------------------------	---