

Spannzangenschlüssel
Clamping wrench
240

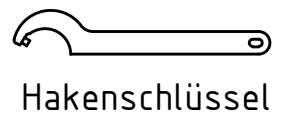

Hakenschlüssel
mit Zapfen
Hook wrench
with fixed pin
DIN1810 B 58x62

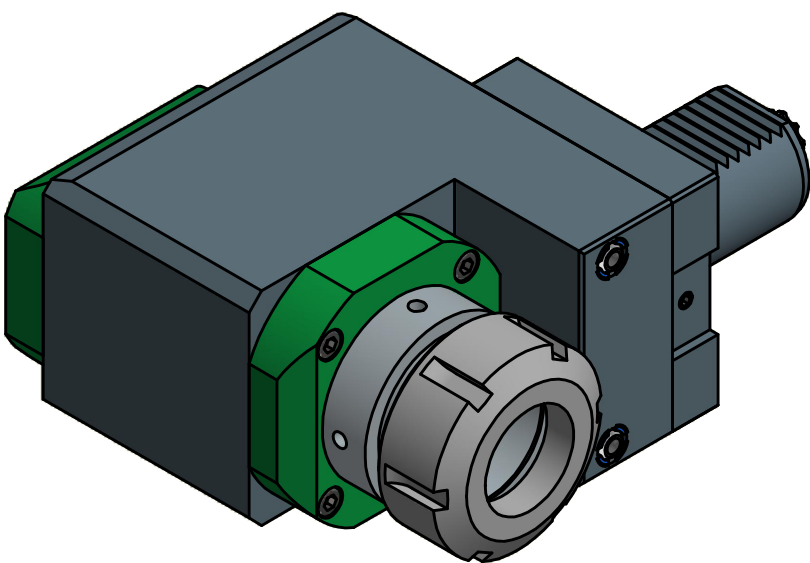
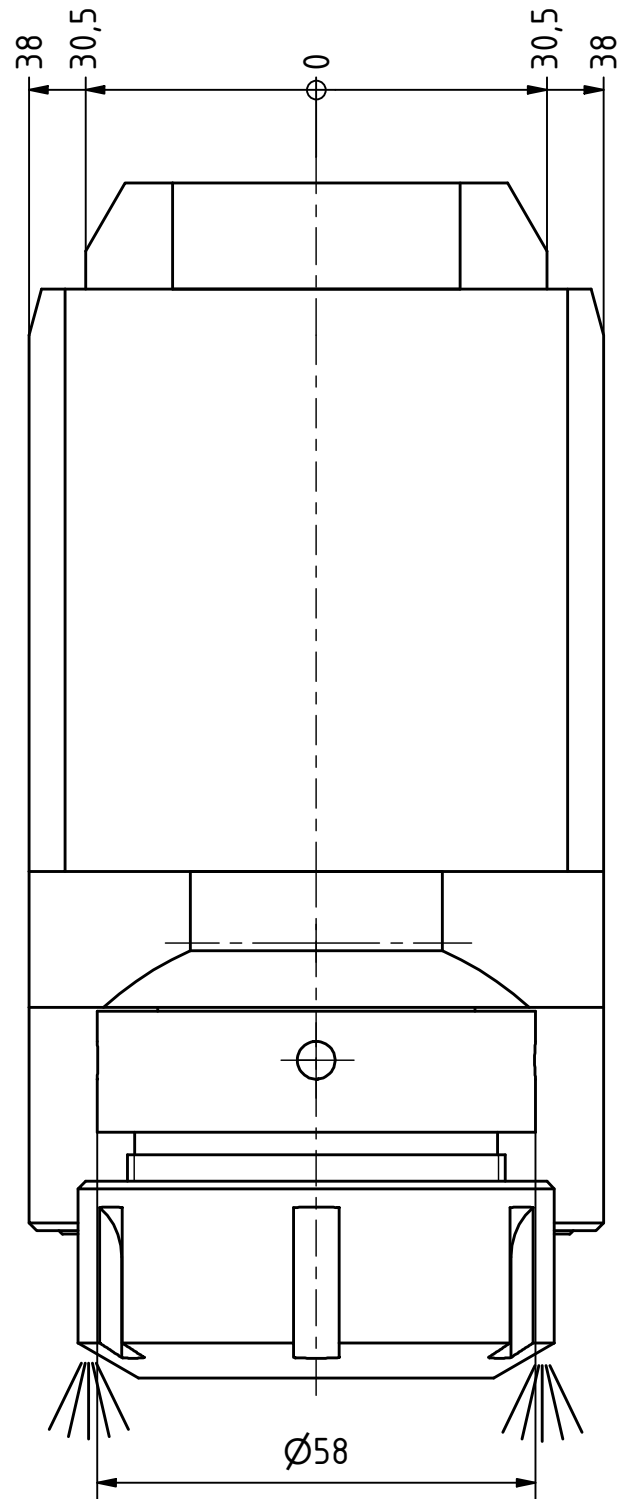
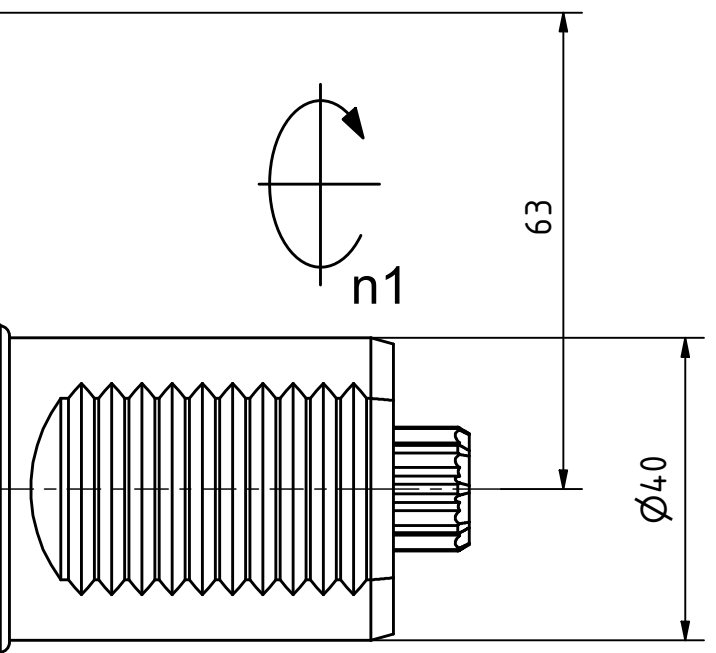

Spannzange / collet ER40 DIN6499
Spannbereich / clamping range: 3,0 - 26,0

Gewindebohrzange / tapping collet
ET-1-40 M6-M16

Copyright **EWS Tool Technologies**
Weitergabe und Vervielfaeltigung dieser Unterlage,
Verwertung und Mitteilung ihres Inhalts nicht
gestattet, soweit nicht ausdrecklich zugestanden.
Zuwiderhandlungen verpflichten zu Schadenersatz.

Bemerkung - Note
mit Kegelrollenlager
with taper roller bearing(s)

Technische Daten - technical data
Weight = 7.858 [kg]
Torque max. (M1/M2) = 40 / 80 [Nm]
Speed max. (n1/n2) = 6000 / 3000 [1/min]
Gear ratio (i)=n1:n2 = 2:1

Benennung - Title
Radial Bohr und Fräskopf, zurückges
Radial drill. and mill. head offset

EWS Tool Technologies
EWS Weigle GmbH & Co. KG
Maybachstr. 1
D-73066 UHINGEN
www.ews-tools.de
Nr. - No.
80.4040KR5482R12

Technische Aenderungen vorbehalten!
Subject to technical modifications!
IDENT: D-EWS-144137
MNR.
170533

