

Spannzange / collet ER25 DIN6499  
 Spannungsbereich / clamping range: 1,0 - 16,0

Gewindebohrzange / tapping collet  
 ET-1-25 M3-M12

Z (2:1)

Ausrichtklotz ist über ein Exzenter einstellbar  
 The block is adjustable via eccentric

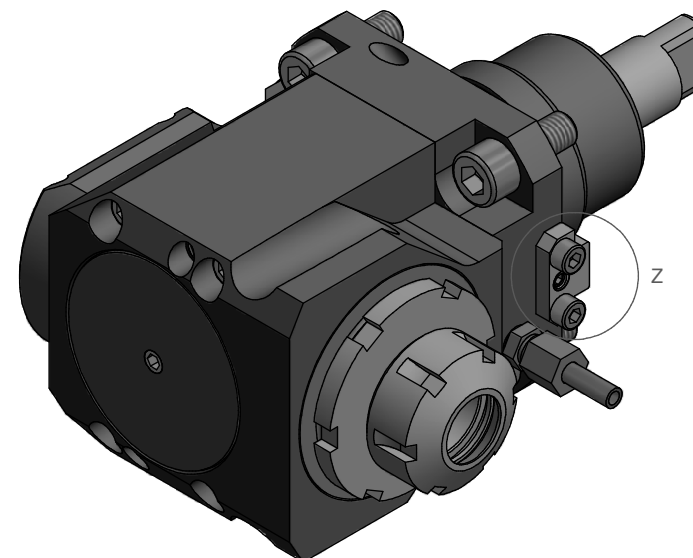
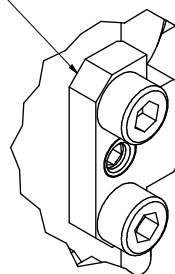

Hakenschlüssel  
 mit Nase  
 Hook wrench with  
 nose end  
**DIN1810 A 58x62**



Spannzangenschlüssel  
 Clamping wrench  
**225**

Copyright **EWS Tool Technologies**  
 Weitergabe und Vervielfältigung dieser Unterlage,  
 Verwertung und Mitteilung ihres Inhalts nicht  
 gestattet, soweit nicht ausdrücklich zugestanden.  
 Zuwiderhandlungen verpflichten zu Schadenersatz.

Bemerkung - Note

Technische Daten - Technical data

Weight = 5,981 [kg]  
 Torque max. (M1/M2) = 50 / 25 [Nm]  
 Speed max. (n1/n2) = 6000 / 12000 [1/min]  
 Gear ratio (i)=n1:n2 = 1:2

Benennung - Title

**Radial Bohr und Fräskopf**  
**Radial drilling and milling head**



Nr. - No.  
**60.5525BIG180911X70**

Technische Änderungen vorbehalten!  
 Subject to technical modifications!

IDENT: DEWS019927



REV: -/A

1998



**168478**