

Doppelverzahnung Lizenz Traub
double tooth system licence Traub

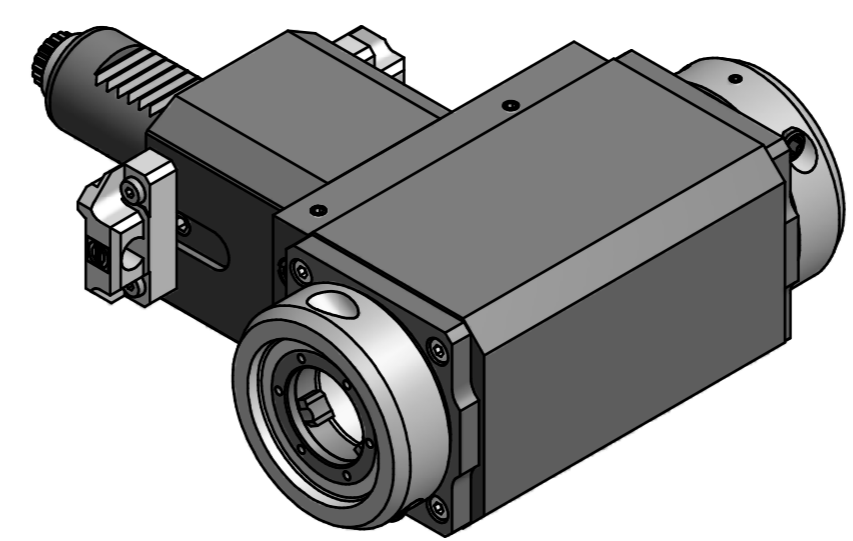

Innen- und Aussenkuehlung / Inside and outside coolant supply
Kein Trockenlauf / No dry run
Kuehlmittelfiltrierung < 50µ / coolant filtration < 50µ

Bemerkung - Note
Nicht ohne Kuehlmittel betreiben!
Not for use without coolant-fluid!

Technische Daten - technical data	
Weight	= 6.797 [kg]
Torque max. (M1/M2)	= 25 / 25 each Sp. [Nm]
Speed max. (n1/n2)	= 8000 / 8000 [1/min]
Gear ratio (i)=n1:n2	= 1:1
Pressure (pmax)	= 25 [bar]

Benennung - Title
Radial Bohr und Fräskopf
Radial drilling and milling head

 EWS Weigle GmbH & Co. KG Maybachstr. 1 D-73066 Uhlringen www.ews-tools.de	Technische Aenderungen vorbehalten! Subject to technical modifications! IDENT: D-EWS-142699	 REV: A/- MNR:
	Nr. - No. 60.30VX3LDCTXRLIKTR	
		166317

Copyright **EWS Tool Technologies**
Weitergabe und Vervielfaeltigung dieser Unterlage,
Verwertung und Mitteilung ihres Inhalts nicht
gestattet, soweit nicht ausdrecklich zugestanden.
Zuwoerhandlungen verpflichten zu Schadenersatz.

