

Spannzange / collet ER25 DIN6499  
Spannbereich / clamping range: 1,0 - 16,0

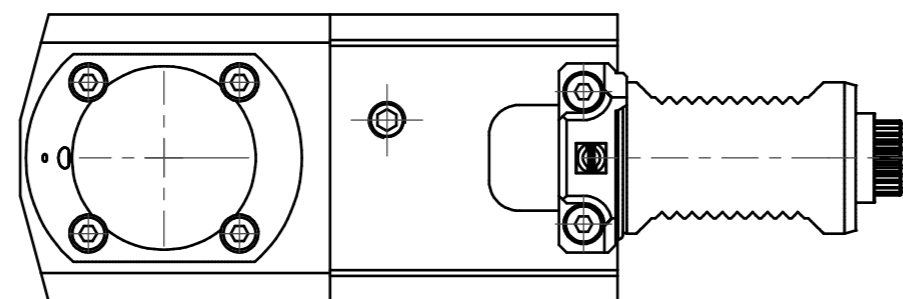

Doppelverzahnung Lizenz Traub  
double tooth system licence Traub

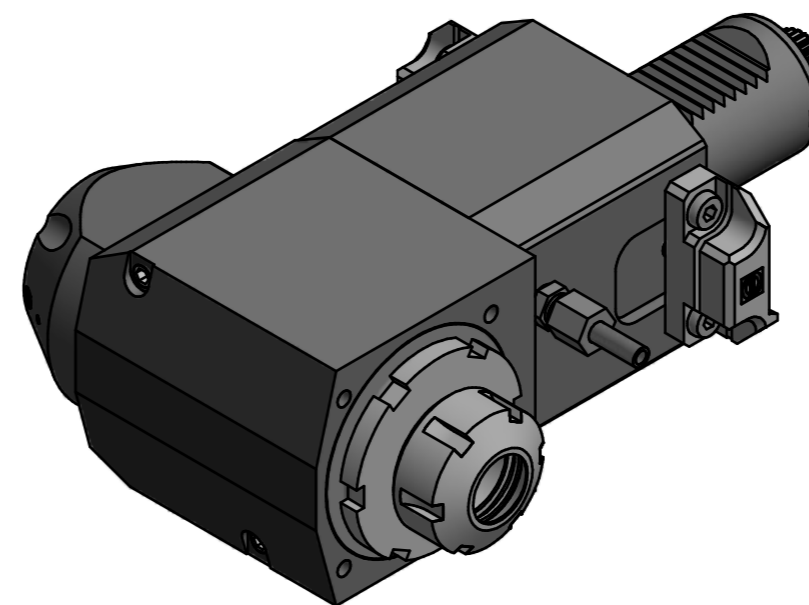
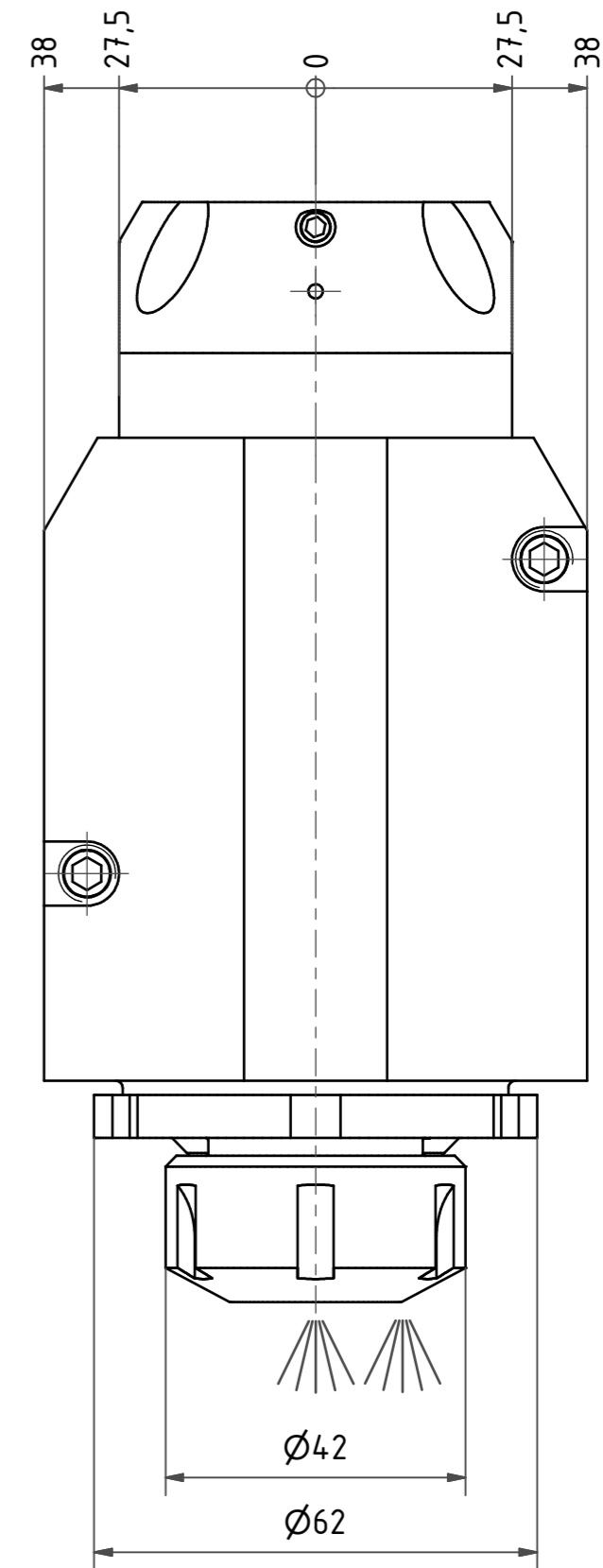
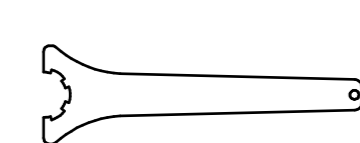

Spannzangenschlüssel  
Clamping wrench  
225

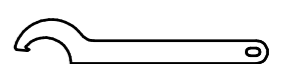

Hakenschlüssel  
mit Nase  
Hook wrench with  
nose end  
DIN1810 A 58x62

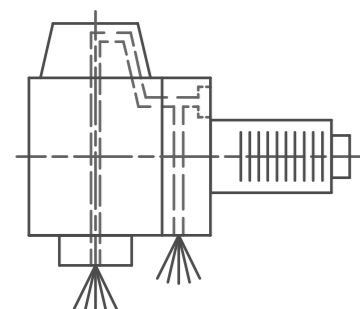

Innen- und Aussenkuehlung / Inside and outside coolant supply  
Kein Trockenlauf / No dry run  
Kuehlmittelfiltrierung=50 $\mu$  / coolant filtration=50 $\mu$

Bemerkung - Note  
Nicht ohne Kuehlmittel betreiben!  
Not for use without coolant-fluid!

Technische Daten - technical data  
Weight = 7.690 [kg]  
Torque max. (M1/M2) = 50 / 25 [Nm]  
Speed max. (n1/n2) = 6000 / 12000 [1/min]  
Gear ratio (i)=n1:n2 = 1:2  
Pressure (pmax) = 25 [bar]

Benennung - Title  
Radial Bohr und Fräskopf  
Radial drilling and milling head

**EWS** Tool Technologies  
EWS Weigle GmbH & Co. KG  
Maybachstr. 1  
D-73066 Uhlringen  
www.ews-tools.de

Technische Aenderungen vorbehalten!  
Subject to technical modifications!

IDENT: D-EWS-211004  
REV: -/-  
MNR.  
167995



Copyright **EWS Tool Technologies**  
Weitergabe und Vervielfaeltigung dieser Unterlage,  
Verwertung und Mitteilung ihres Inhalts nicht  
gestattet, soweit nicht ausdrucklich zugestanden.  
Zuwaerdigungen verpflichten zu Schadenersatz.