

Spannzange / collet ER25 DIN6499
 Spannungsbereich / clamping range: 1,0 - 16,0

Gewindebohrzange / tapping collet
 ET-1-25 M3-M12

Ausrichtklotz ist über
 ein Exzenter einstellbar.
 The block is adjustable
 via eccentric.

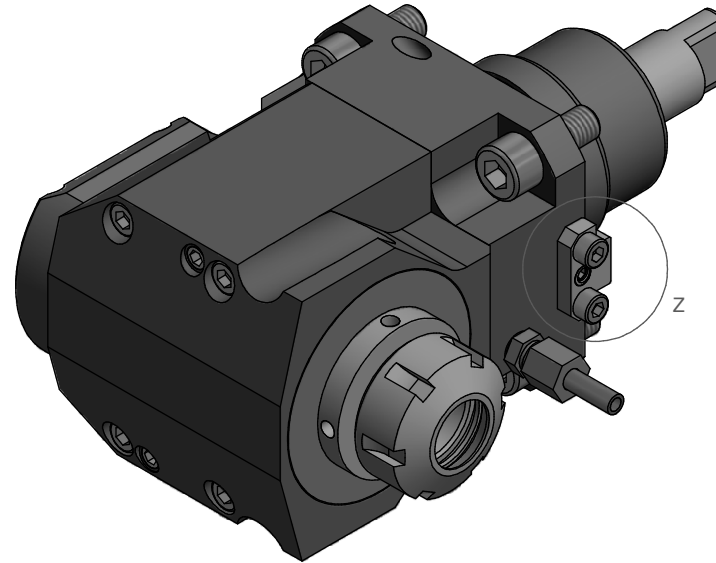
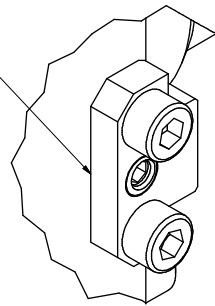

Hakenschlüssel
 mit Zapfen
 Hook wrench
 with fixed pin
 DIN1810 B 45x50



Spannzangenschlüssel
 Clamping wrench
 225

Copyright EWS Tool Technologies
 Weitergabe und Vervielfältigung dieser Unterlage,
 Verwertung und Mitteilung ihres Inhalts nicht
 gestattet, soweit nicht ausdrücklich zugestanden.
 Zuwiderhandlungen verpflichten zu Schadenersatz.

Bemerkung - Note

Technische Daten - Technical data

Weight = 6.314 [kg]
 Torque max. (M1/M2) = 50 / 50 [Nm]
 Speed max. (n1/n2) = 6000 / 6000 [1/min]
 Gear ratio (i)=n1:n2 = 1:1

Benennung - Title

Radial Bohr und Fräskopf
 Radial drilling and milling head

EWS EWS Werkzeug GmbH & Co. KG
 Tool Technologies D-72086 Löhningen
 www.ews-tool.de

Nr. - No. 60.5525BIG1809GLX80

Technische Änderungen vorbehalten!
 Subject to technical modifications!

IDENT: DEWS019918



REV: -/A

ppb

166261

