

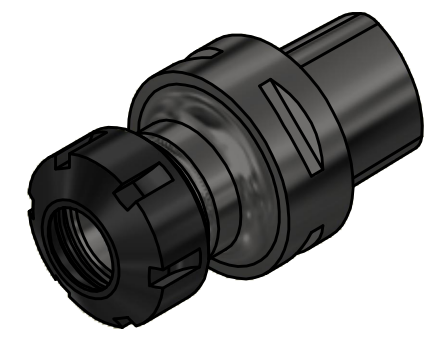

Polygon ISO 26623 PSC 50



Spannzange / collet ER25 DIN6499
 Spannbereich / clamping range: 1,0 - 16,0

Gewindebohrzange / tapping collet
 ET-1-25 M3-M12

Copyright **EWS Tool Technologies**
 Weitergabe und Vervielfaeltigung dieser Unterlage,
 Verwertung und Mitteilung ihres Inhalts nicht
 gestattet, soweit nicht ausdrecklich zugestanden.
 Zuwiderhandlungen verpflichten zu Schadenersatz.

Bemerkung - Note	Technische Daten - technical data Weight = 0.628 [kg]	Benennung - Title Spannzangenaufnahme <i>Collet chuck holder</i>	 EWS <small>EWS Weigele GmbH & Co. KG Maybachstr. 1 D-73066 Uhingen www.ews-tools.de</small>	Technische Aenderungen vorbehalten! <i>Subject to technical modifications!</i> IDENT: DEWS238027 Nr. - No. 31.C525L60	 REV: -/A MNR. 167739	
------------------	--	---	--	--	--	---