

Innen- und Aussenkuehlung
Inside and outside coolant supply

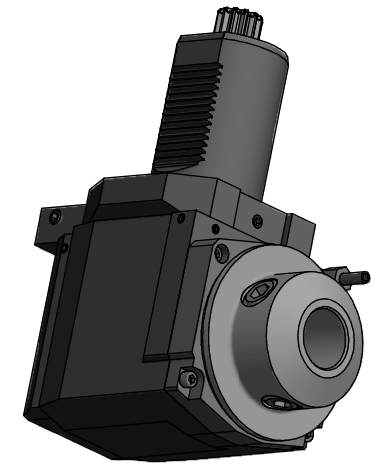

Copyright **EWS Tool Technologies**
Weitergabe und Vervielfaeltigung dieser Unterlage,
Verwertung und Mitteilung ihres Inhalts nicht
gestattet, soweit nicht ausdrecklich zugestanden.
Zuwaenderungen verpflichten zu Schadenersatz.

<p>Bemerkung - Note Nicht ohne Kuehlmittel betreiben! Not for use without coolant-fluid!</p>	<p>Technische Daten - Technical data Weight = 13,092 [kg] Torque max. (M1/M2) = 140 / 280 [Nm] Speed max. (n1/n2) = 3000 / 1500 [1/min] Gear ratio (i1)=n1:n2 = 2:1 Pressure (pmax) = 70 [bar]</p>	<p>Benennung - Title Radial Bohr und Fraskopf Radial drilling and milling head</p>	<p>EWS Tool Technologies EWS Werkzeug GmbH & Co. KG D-72088 Löhningen www.ews-tool.de</p> <p>Technische Änderungen vorbehalten! Subject to technical modifications! IDENT: D-EWS-047959</p> <p>REV: -/- ppk</p> <p>60.6032WNKR5482RIK12</p> <p>137162</p>
---	---	---	--

