

min 77,5
max 81

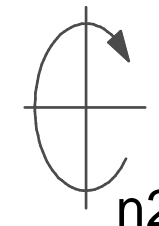

Spannzange / collet ER25 DIN6499
Spannbereich / clamping range: 1,0 - 16,0

Gewindebohrzange / tapping collet
ET-1-25 M3-M10

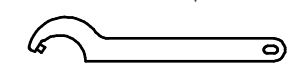
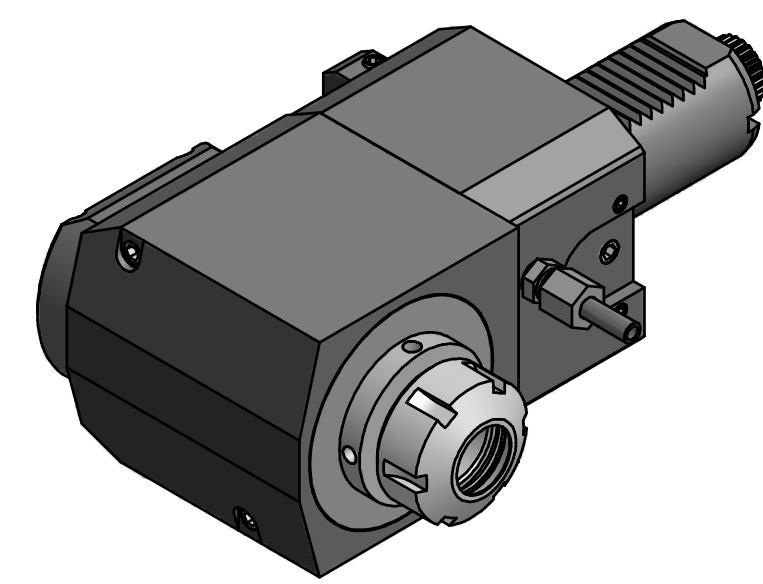

Hakenschlüssel
mit Zapfen
Hook wrench
with fixed pin
DIN1810 B 45x50

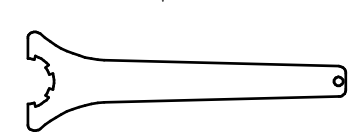

Spannzangenschlüssel
Clamping wrench
225

Copyright **EWS Tool Technologies**
Weitergabe und Vervielfaeltigung dieser Unterlage,
Verwertung und Mitteilung ihres Inhalts nicht
gestattet, soweit nicht ausdrecklich zugestanden.
Zuwoiderhandlungen verpflichten zu Schadenersatz.

| | | | | | | | |
|------------------|---|---|--|-------------|--|--------|-------------|
| Bemerkung - Note | Technische Daten - technical data M1 / M2 = 50 / 50 Nm n1 / n2 = 6000 / 6000 1/min i (N1:N2) = 1:1 | Benennung - Title Radial Bohr und Fräskopf <i>Radial drilling and milling head</i> | name | date | Technische Aenderungen vorbehalten! Subject to technical modifications! | | |
| | | | drawing | Kratschmann | | | 23.09.2013 |
| | | | | | Nr. 60.4025CTXRGL | DIN A3 | |
| | | | EWS Weigete GmbH & Co. KG Maybachstr. 1 D-73066 Uhingen Tel. +49(0)7161/93040-100 | | | | MNR: 170346 |