

Spannzange / collet ER32 DIN6499
 Spannungsbereich / clamping range: 2,0 - 20,0

Hakenschlüssel mit Nase / Hook wrench with nose end
 DIN1810 A 58x62

Spannzangenschlüssel für innenliegende Mutter / Clamping wrench for internal collet
 232AX

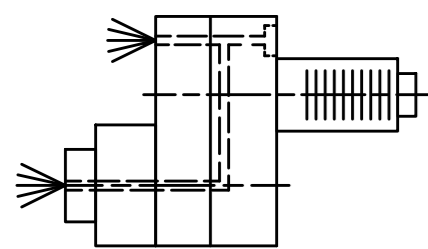

Innen- und Aussenkuehlung / Inside and outside coolant supply
 Kuehlmittelfiltrierung-50µ / coolant filtration-50µ

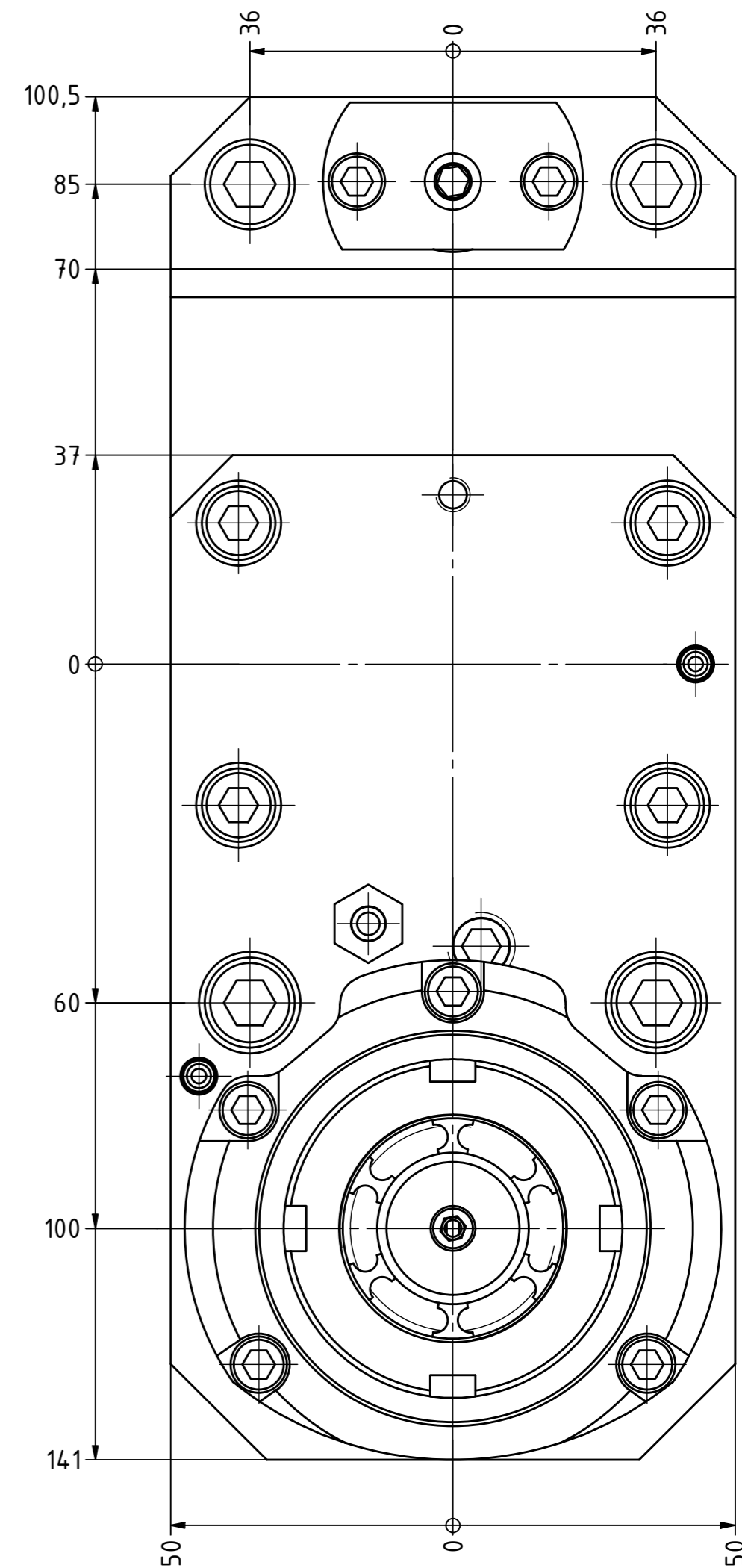
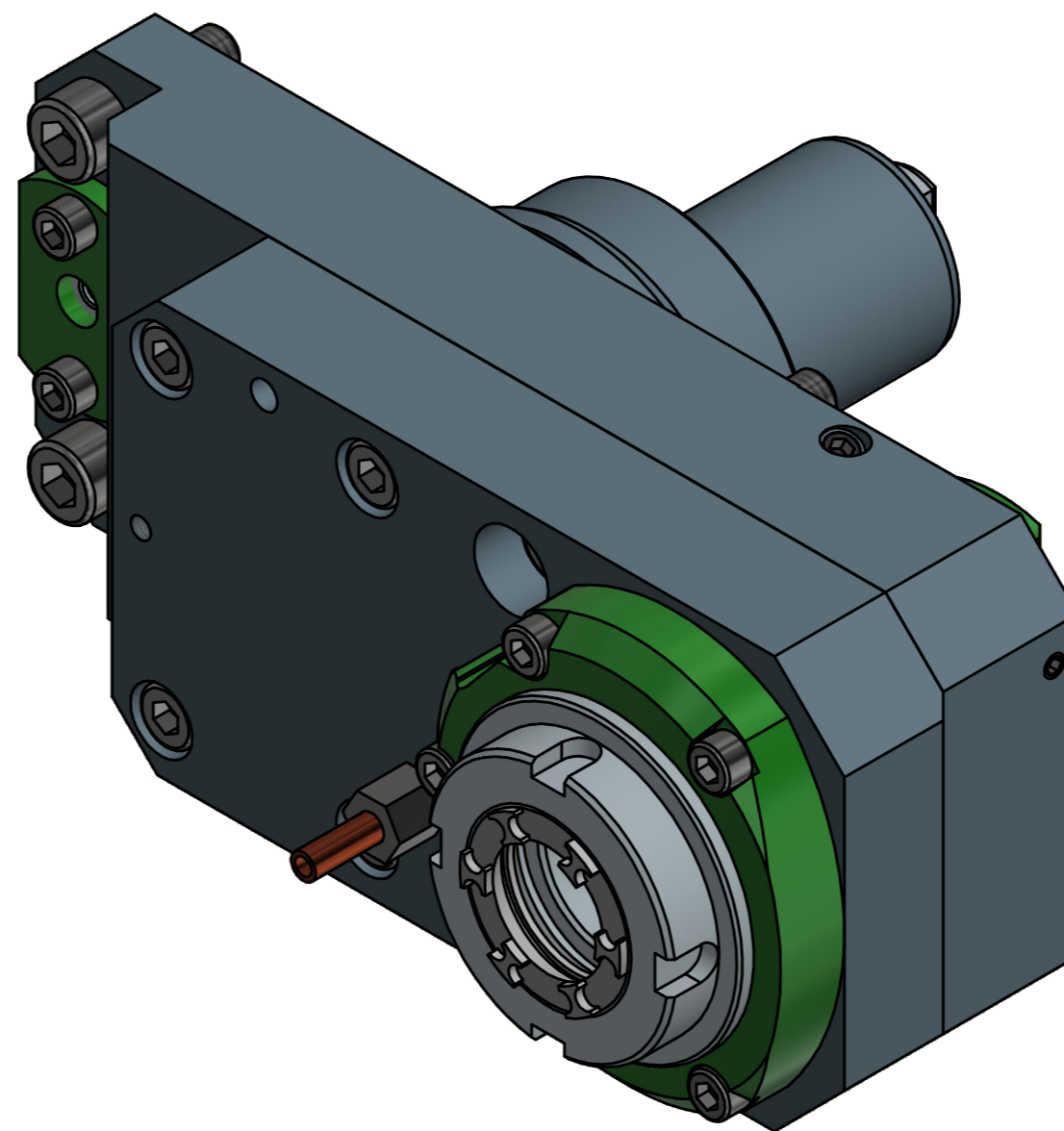

Copyright **EWS Tool Technologies**
 Weitergabe und Vervielfaeltigung dieser Unterlage,
 Verwertung und Mitteilung ihres Inhalts nicht
 gestattet, soweit nicht ausdrecklich zugestanden.
 Zuwiderhandlungen verpflichten zu Schadenersatz.

Bemerkung - Note Für Trockenlauf geeignet! Use without coolant fluid allowed!	Technische Daten - technical data Weight = 10.640 [kg]
	Torque max. (M1/M2) = 100 / 100 [Nm]
	Speed max. (n1/n2) = 6000 / 6000 [1/min]
	Gear ratio (i)=n1:n2 = 1:1
	Pressure (pmax) = 70 [bar]

Benennung - Title
Axial Bohr u. Fräskopf achsversetzt
Ax. drill. and mill. head offset



Nr. - No.
50.8032QSMBMTIKDIM

Technische Aenderungen vorbehalten!
 Subject to technical modifications!
 IDENT: DEWS049887

REV: -/A
 MNR.

167451

