

Hydrodehnfutter / hydraulic chuck NBC-20/25-46

Hülsen / collets 28.20xxHYDSP

XX (Ø) 3 4 5 6 7 8 9 10 12 14 16
1/8 3/16 1/4 5/16 3/8 7/16 1/2 9/16 5/8

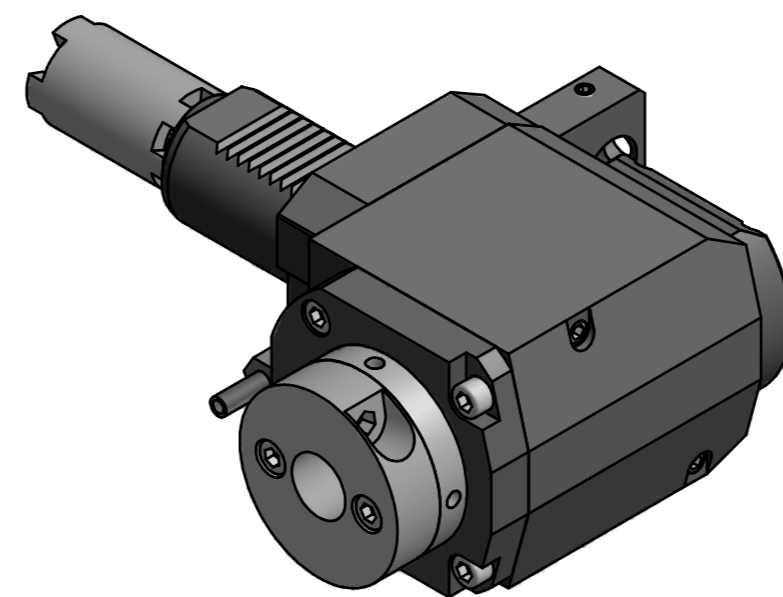
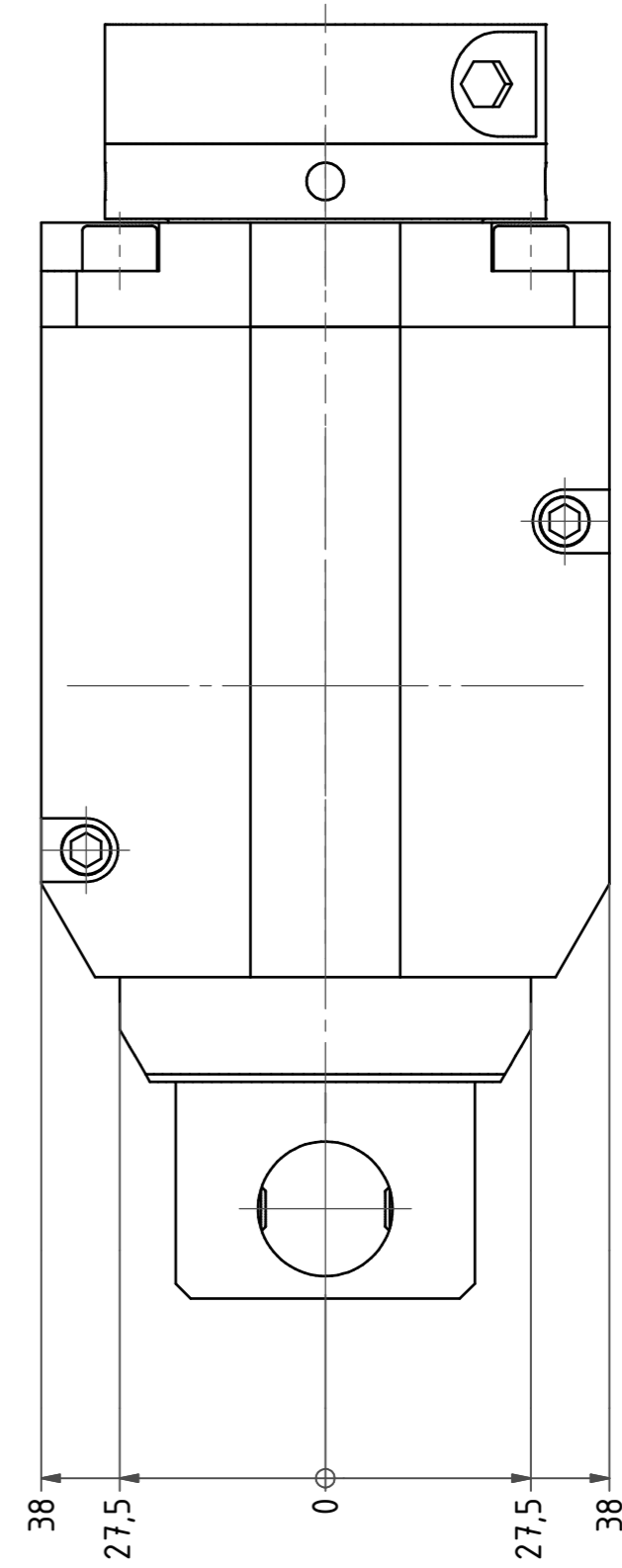
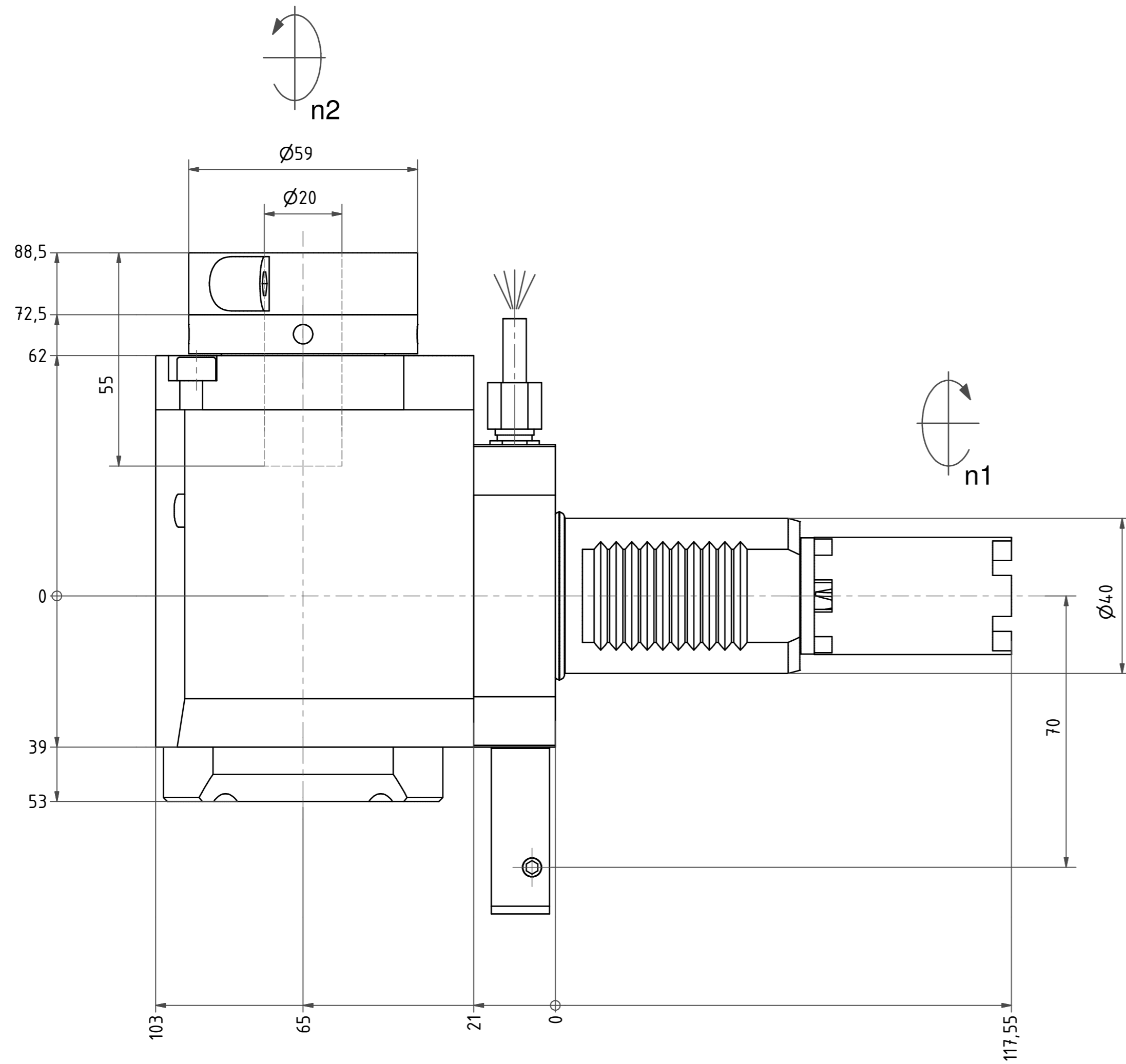

Copyright **EWS Tool Technologies**
Weitergabe und Vervielfältigung dieser Unterlage,
Verwertung und Mitteilung ihres Inhalts nicht
gestattet, soweit nicht ausdrücklich zugestanden.
Zuwendungen verpflichten zu Schadenersatz.

<p>Benennung - Title</p> <p>Radial Bohr und Fräskopf <i>Radial drilling and milling head</i></p>	<p>Technische Daten - technical data</p> <p>Weight = 6.278 [kg] Torque max. (M1/M2) = 50 / 50 [Nm] Speed max. (n1/n2) = 6000 / 6000 [1/min] Gear ratio (i)=n1:n2 = 1 : 1</p>	<p>Benennung - Title</p> <p>Radial Bohr und Fräskopf <i>Radial drilling and milling head</i></p>	<p>EWS <small>EWS Weigle GmbH & Co. KG Maybachstr. 1 D-73066 Uhlringen www.ews-tools.de</small></p> <p>Nr. - No. 60.4020HYDHAASSL40L</p>	<p>Technische Änderungen vorbehalten! Subject to technical modifications!</p> <p>IDENT: D-EWS-196929</p> <p>REV: -/-</p> <p>MNR. 166156</p>	<p>QR</p>
---	--	---	--	--	-----------