

Spannzange / collet ER32 DIN6499
Spannbereich / clamping range: 2,0 - 20,0

Gewindebohrzange / tapping collet
ET-1-32 M5-M12

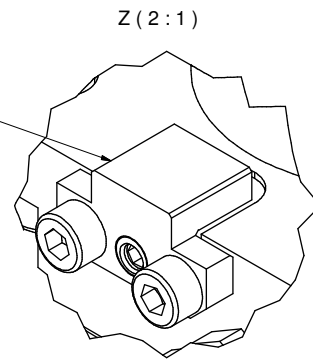

Ausrichtklotz ist über ein Exzenter einstellbar.
The block is adjustable via eccentric.

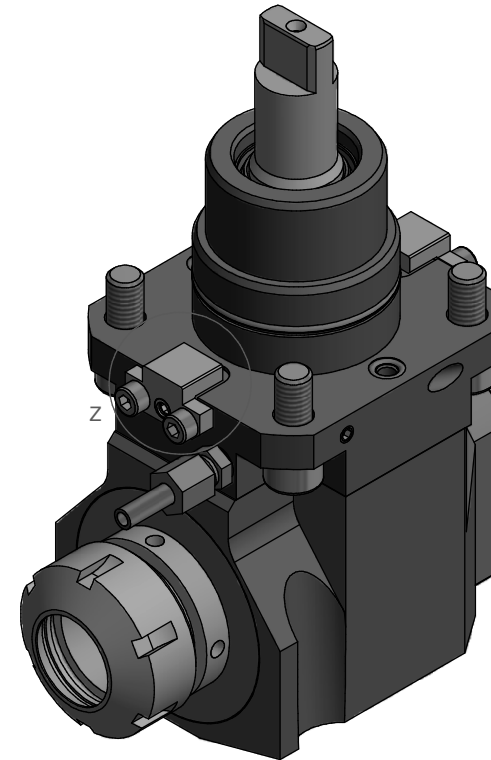
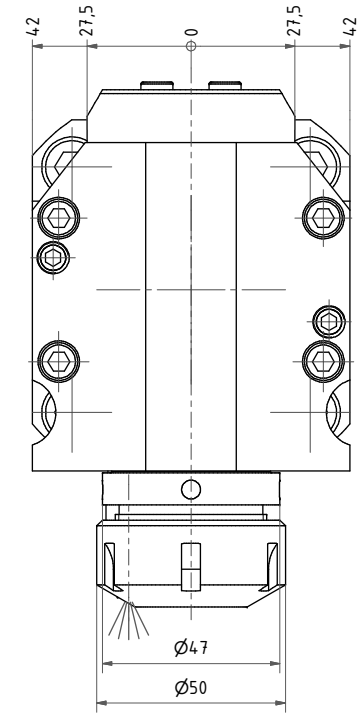
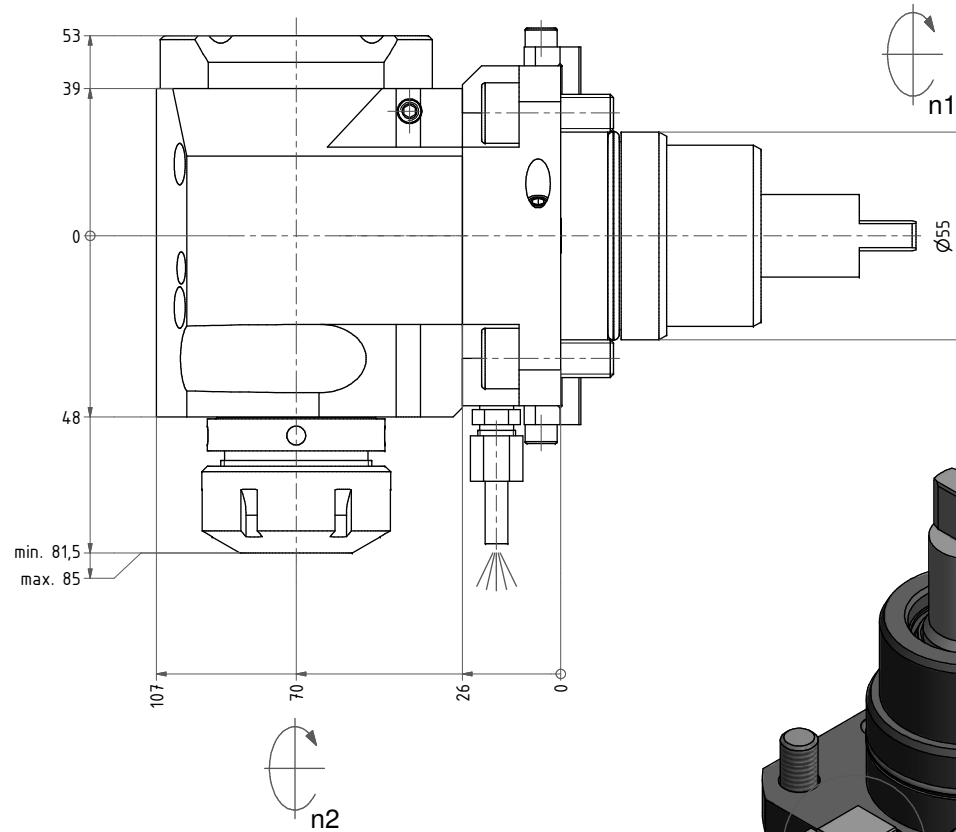

Hakenschlüssel mit Zapfen
Hook wrench with fixed pin
DIN1810 B 45x50

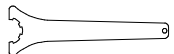

Spannzangenschlüssel
Clamping wrench
232

Bemerkung - Note

Technische Daten - Technical data

Weight = 5,888 [kg]
Torque max. (M1/M2) = 50 / 50 [Nm]
Speed max. (n1/n2) = 6000 / 6000 [1/min]
Gear ratio (i)=n1:n2 = 1:1

Benennung - Title

Radial Bohr und Fräskopf
Radial drilling and milling head



Nr. - No.
60.5532BIG1809GLX70

Technische Änderungen vorbehalten!
Subject to technical modifications!

IDENT: DEWS019743



REV: -/A
1988

Copyright EWS Tool Technologies
Weitergabe und Vervielfältigung dieser Unterlage,
Verwertung und Mitteilung ihres Inhalts nicht
gestattet, soweit nicht ausdrücklich zugestanden.
Zuwendungen verpflichten zu Schadenersatz.

