

Spannzange / collet ER32 DIN6499  
 Spannungsbereich / clamping range: 2,0 - 20,0

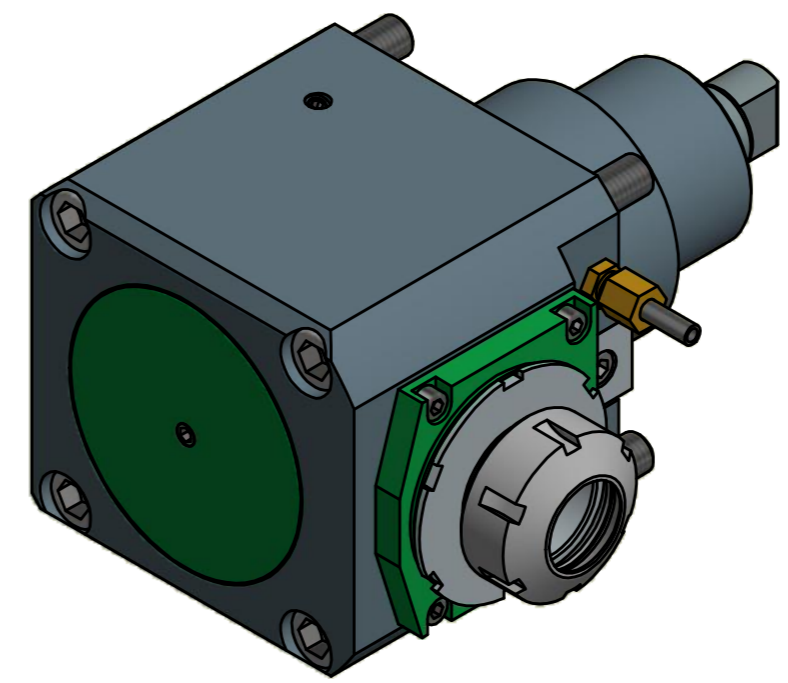

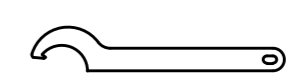

  
 Hakenschlüssel  
 mit Nase  
 Hook wrench with  
 nose end  
 DIN1810 A 68x75

  
 Spannzangenschlüssel  
 Clamping wrench  
 232

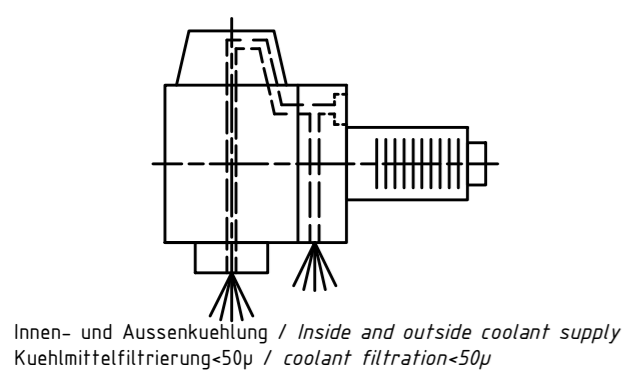
Copyright **EWS Tool Technologies**  
 Weitergabe und Vervielfältigung dieser Unterlage,  
 Verwertung und Mitteilung ihres Inhalts nicht  
 gestattet, soweit nicht ausdrücklich zugestanden.  
 Zuwiderhandlungen verpflichten zu Schadenersatz.



Bemerkung - Note Für Trockenlauf geeignet! Use without coolant fluid allowed!	Technische Daten - technical data Weight = 11,098 [kg] Torque max. (M1/M2) = 100 / 50 [Nm] Speed max. (n1/n2) = 4000 / 8000 [1/min] Gear ratio (i)=n1:n2 = 1:2 Pressure (pmax) = 70 [bar]	Benennung - Title Radial Bohr und Fräskopf Radial drilling and milling head	 EWS Weigle GmbH & Co. KG Maybachstr. 1 D-73066 Uhlingen www.ews-tool.de Nr. - No. 60.75321809IKD11	Technische Änderungen vorbehalten! Subject to technical modifications! IDENT: DEWS021466 REV: -/A MNR. 136036	
---	--	---	---	--	---