

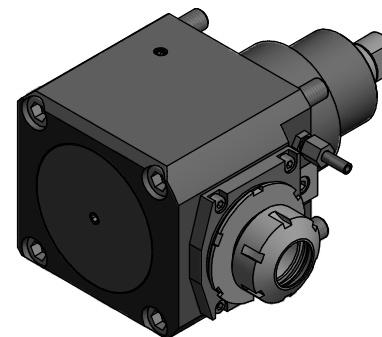

Spannzange / collet ER32 DIN6499
 Spannbereich / clamping range: 2,0 - 20,0

Gewindebohrzange / tapping collet
 ET-1-32 M5-M12

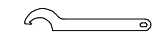

 Hakenschlüssel
 mit Nase
 Hook wrench with
 nose end
 DIN1810 A 68x75

 Spannzangenschlüssel
 Clamping wrench
 232

Copyright **EWS Tool Technologies**
 Weitergabe und Vervielfältigung dieser Unterlage,
 Verwertung und Mitteilung ihres Inhalts nicht
 gestattet, soweit nicht ausdrücklich zugestanden.
 Zuwiderhandlungen verpflichten zu Schadenersatz.

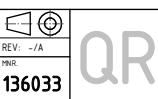
Bemerkung - Note	Technische Daten - Technical data Weight = 11,035 [kg] Torque max. (M1/M2) = 100 / 50 [Nm] Speed max. (n1/n2) = 4.000 / 8000 [1/min] Gear ratio (i)=n1:n2 = 1:2	Benennung - Title Radial Bohr und Fräskopf <i>Radial drilling and milling head</i>	 Nr. - No. 60.753218091	Technische Änderungen vorbehalten! Subject to technical modifications! IDENT: DEWS02N57 REV: -/A 136033	
------------------	---	---	---	---	---