

min. 128,5
max. 135,5

Spannzange / collet ER50 DIN6499
Spannbereich / clamping range: 6,0 - 34,0

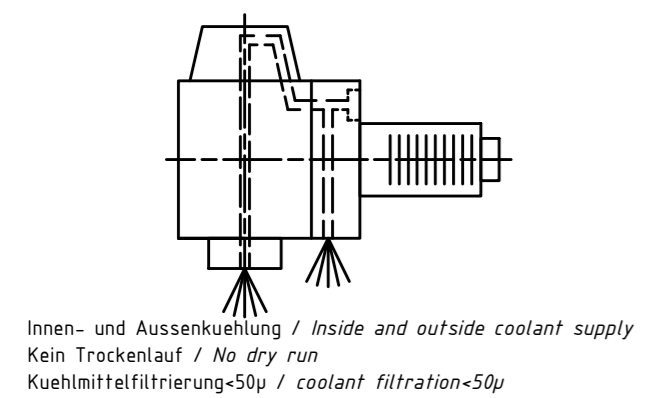
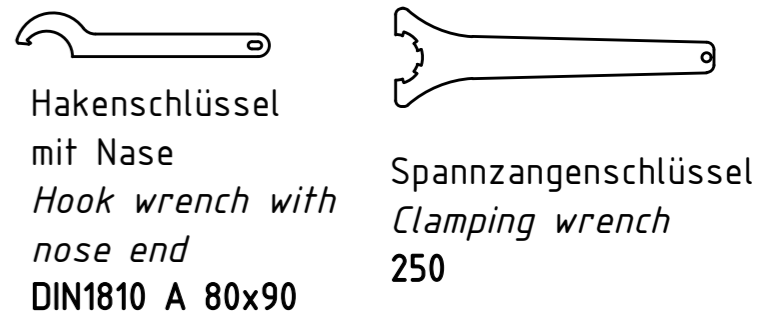
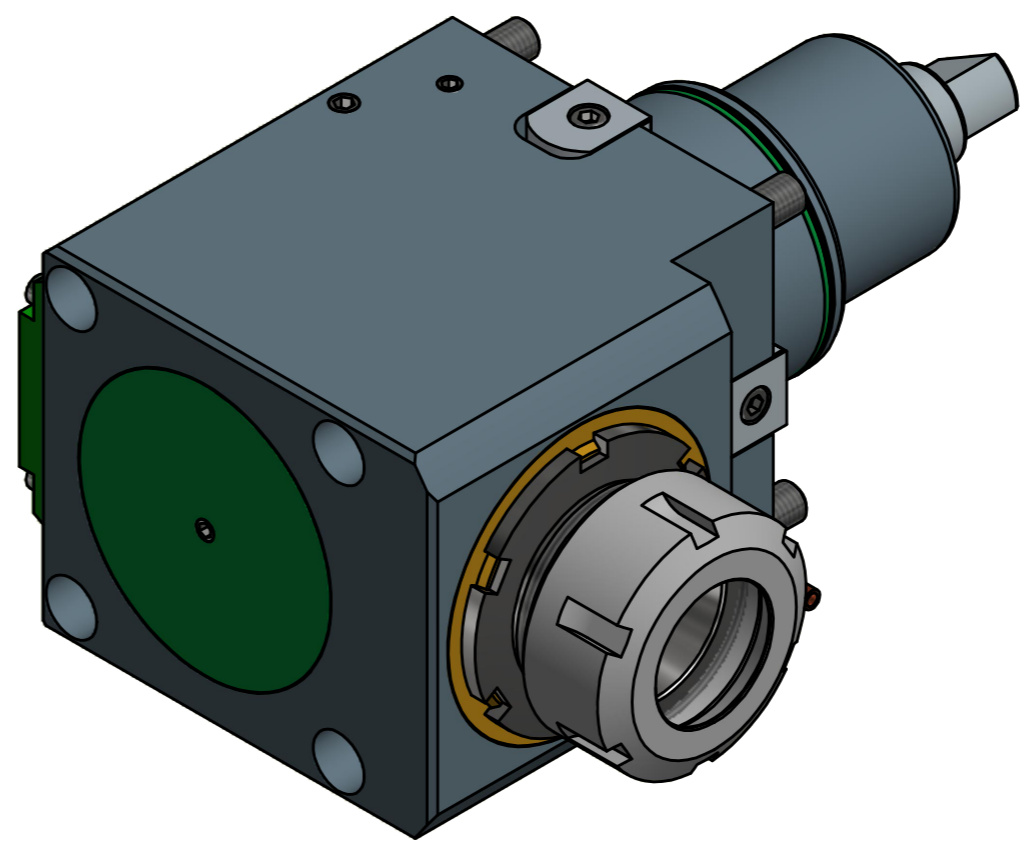
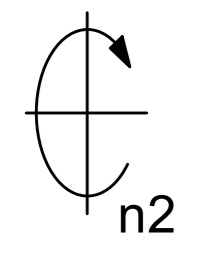

Copyright **EWS Tool Technologies**
Weitergabe und Vervielfaeltigung dieser Unterlage, Verwertung und Mitteilung ihres Inhalts nicht gestattet, soweit nicht ausdrecklich zugestanden. Zuwiderhandlungen verpflichten zu Schadenersatz.

<p>Bemerkung - Note Nicht ohne Kuehlmittel betreiben! Not for use without coolant-fluid!</p>	<p>Technische Daten - technical data Weight = 21,444 [kg] Torque max. (M1/M2) = 100 / 100 [Nm] Speed max. (n1/n2) = 4000 / 4000 [1/min] Gear ratio (i)=n1:n2 = 1:1 Pressure (pmax) = 70 [bar]</p>	<p>Benennung - Title Radial Bohr und Fräskopf Radial drilling and milling head</p>	<p>EWS Tool Technologies EWS Weigle GmbH & Co. KG Maybachstr. 1 D-73066 Uhlingen www.ews-tools.de</p>	<p>Technische Aenderungen vorbehalten! Subject to technical modifications! IDENT: DEWS132879 REV: -/B MNR. 166096</p>	<p>QR</p>
--	---	--	--	---	------------------