

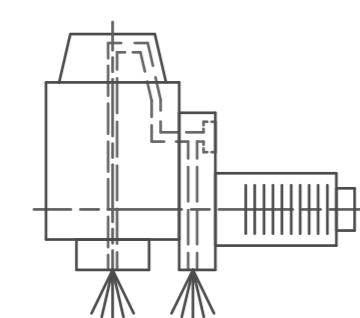

Spannzange / collet ER40 DIN6499
Spannbereich / clamping range: 3,0 - 26,0

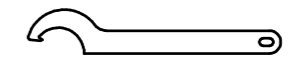

Innen- und Aussenkuehlung
inside and outside coolant supply



Hakenschlüssel
mit Nase
Hook wrench with
nose end
DIN1810 A 80x90

Spannzangenschlüssel
Clamping wrench
240

Copyright **EWS Tool Technologies**
Weitergabe und Vervielfaeltigung dieser Unterlage,
Verwertung und Mitteilung ihres Inhalts nicht
gestattet, soweit nicht ausdruercklich zugestanden.
Zuwaerhandlungen verpflichtet zu Schadenersatz.

Bemerkung - Note Nicht ohne Kuehlmittel betreiben! Not for use without coolant-fluid! mit Kegelrollenlagern with taper roller bearings	Technische Daten - technical data M1 / M2 = 160 / 160 Nm n1 / n2 = 3000 / 3000 1/min i (N1:N2) = 1:1 Pmax = 70 bar
--	--

Benennung - Title
Radial Bohr und Fräskopf. zurueckges
Radial drill. and mill. head offset

name	date	Technische Aenderungen vorbehalten! Subject to technical modifications! Nr. 80.6040KR1809RIK MNR: 134523 IDENT: D-EWS-049438 - Blatt - page 1 (1)
drawing	Theiss 03.08.2007	
 EWS Werkzeug GmbH & Co. KG Maybachstr. 1 D-73066 Uffingen Tel. +49(0)716193040-100		DIN A2