

Hakenschlüssel
mit Nase
Hook wrench with
nose end
DIN1810 A 52x55

Spannzangenschlüssel
Clamping wrench
225

Spannzange / collet ER25 DIN6499
Spannbereich / clamping range: 1,0 - 16,0

Gewindebohrzange / tapping collet
ET-1-25 M3-M10

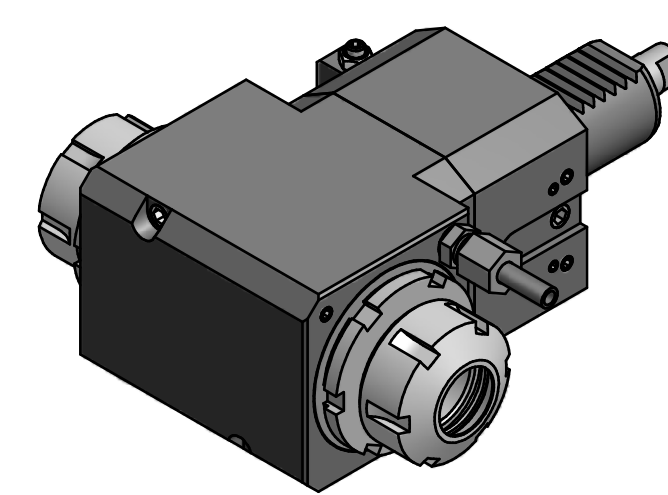

Copyright **EWS Tool Technologies**
Weitergabe und Vervielfaeltigung dieser Unterlage,
Verwertung und Mitteilung ihres Inhalts nicht
gestattet, soweit nicht ausdruuecklich zugestanden.
Zuwiderhandlungen verpflichten zu Schadenersatz.

<p>Bemerkung - Note</p>	<p>Technische Daten - technical data</p> <p>Weight = 4.283 [kg] Torque max. (M1/M2) = 25 / 25 each Sp. [Nm] Speed max. (n1/n2) = 8000 / 8000 [1/min] Gear ratio (i)=n1:n2 = 1:1</p>	<p>Benennung - Title</p> <p>Radial Bohr und Fräskopf <i>Radial drilling and milling head</i></p>	<p>EWS Tool Technologies</p> <p>EWS Weigle GmbH & Co. KG Maybachstr. 1 D-73066 Uthingen www.ews-tools.de</p>	<p>Technische Aenderungen vorbehalten! Subject to technical modifications!</p> <p>IDENT: D-EWS-082591</p>	<p>REV: B/-</p> <p>MNR.</p> <p>167244</p>
			<p>Nr. - No.</p> <p>60.3025D1809PIN48X85</p>		

