

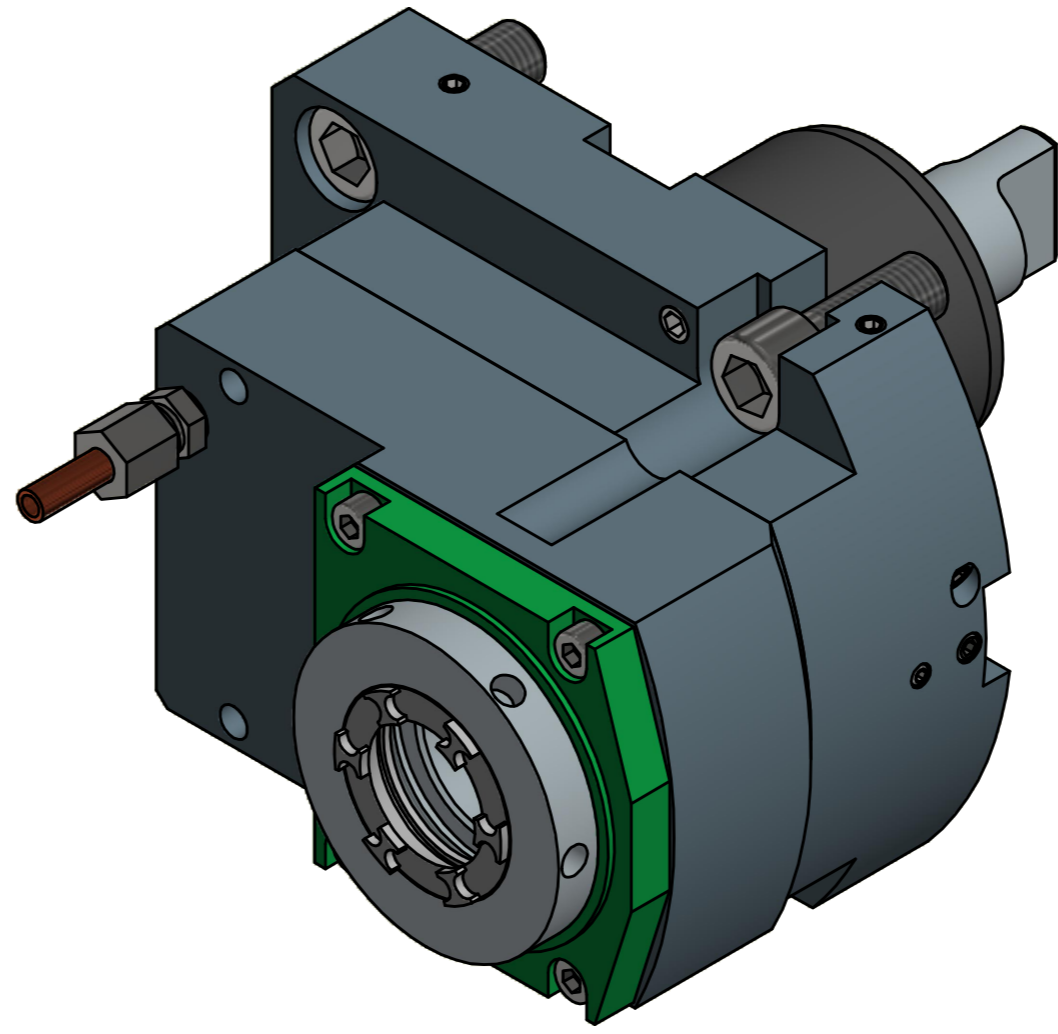

Spannzange / collet ER32 DIN6499
 Spannbereich / clamping range: 2,0 - 20,0

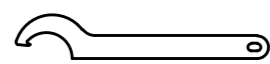
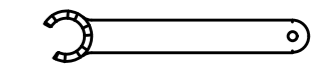

 Hakenschlüssel
 mit Nase
 Hook wrench with
 nose end
 DIN1810 A 58x62

 Spannzangenschlüssel für
 innenliegende Mutter
 Clamping wrench for
 internal collet
 232AX

Copyright **EWS Tool Technologies**
 Weitergabe und Vervielfältigung dieser Unterlage,
 Verwertung und Mitteilung ihres Inhalts nicht
 gestattet, soweit nicht ausdrücklich zugestanden.
 Zuwiderhandlungen verpflichten zu Schadenersatz.

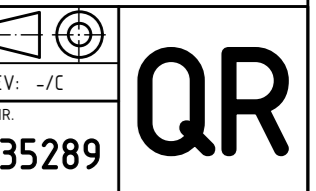
Bemerkung - Note	Technische Daten - technical data Weight = 7.665 [kg] Torque max. (M1/M2) = 50 / 50 [Nm] Speed max. (n1/n2) = 6000 / 6000 [1/min] Gear ratio (i)=n1:n2 = 1:1	Benennung - Title Axial Bohr u. Fräskopf achsversetzt Ax. drill. and mill. head offset	 EWS Weigle GmbH & Co. KG Maybachstr. 1 D-73066 Ulm/ingen www.ews-tools.de Nr. - No. 50.6032NLM	Technische Änderungen vorbehalten! Subject to technical modifications! IDENT: D-EWS-114.082 MNR. 135289	
------------------	--	--	---	--	---