

min. 33  
max. 36,5

Ø42

n2

Spannzange / *collet* ER25 DIN6499  
Spannbereich / *clamping range*: 1,0 - 16,0

Gewindebohrzange / *tapping collet*  
ET-1-25 M3-M12

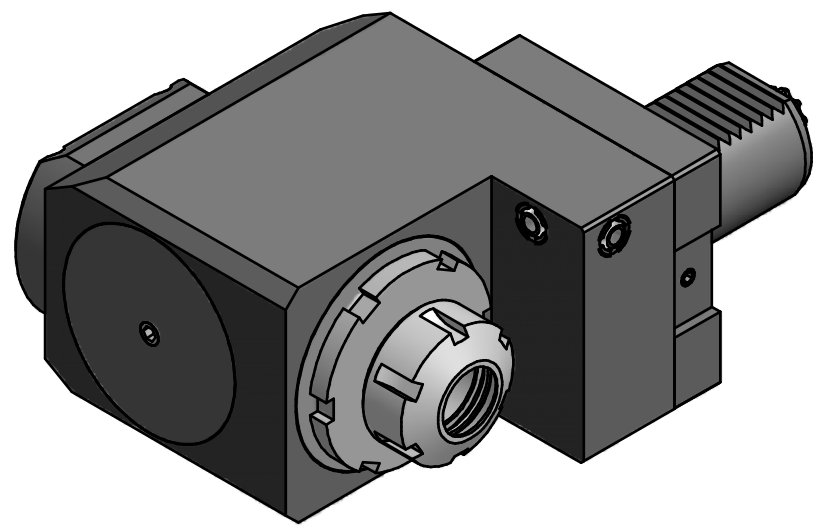

Hakenschlüssel  
mit Nase  
*Hook wrench with  
nose end*  
DIN1810 A 58x62

Spannzangenschlüssel  
*Clamping wrench*  
225

Copyright **EWS Tool Technologies**  
Weitergabe und Vervielfältigung dieser Unterlage,  
Verwertung und Mitteilung ihres Inhalts nicht  
gestattet, soweit nicht ausdrücklich zugestanden.  
Zuwendungen verpflichten zu Schadenersatz.

Bemerkung - <i>Note</i>  	Technische Daten - <i>technical data</i> M1 / M2 = 45 / 15 Nm n1 / n2 = 5000 / 15000 1/min i (N1:N2) = 1:3	Benennung - <i>Title</i> <b>Radial Bohr und Fräskopf. zurückges</b> <b>Radial drill. and mill. head offset</b>	<table border="1"> <tr> <th>name</th> <th>date</th> </tr> <tr> <td>Schmid</td> <td>25.09.2013</td> </tr> </table>	name	date	Schmid	25.09.2013	Technische Änderungen vorbehalten! <i>Subject to technical modifications!</i> Nr. <b>80.40255482RI13</b> MNR: 164.701 IDENT: D-EWS-143604 - Blatt - page 1 (1)
name	date							
Schmid	25.09.2013							

