

Innen- und Aussenkuehlung / Inside and outside coolant supply  
 Kein Trockenlauf / No dry run  
 Kuehlmittelfiltrierung <math>50\mu</math> / coolant filtration <math>50\mu</math>

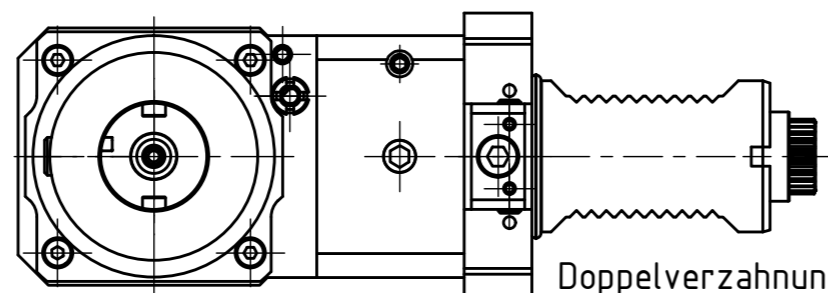

Doppelverzahnung Lizenz Traub  
 double tooth system licence Traub

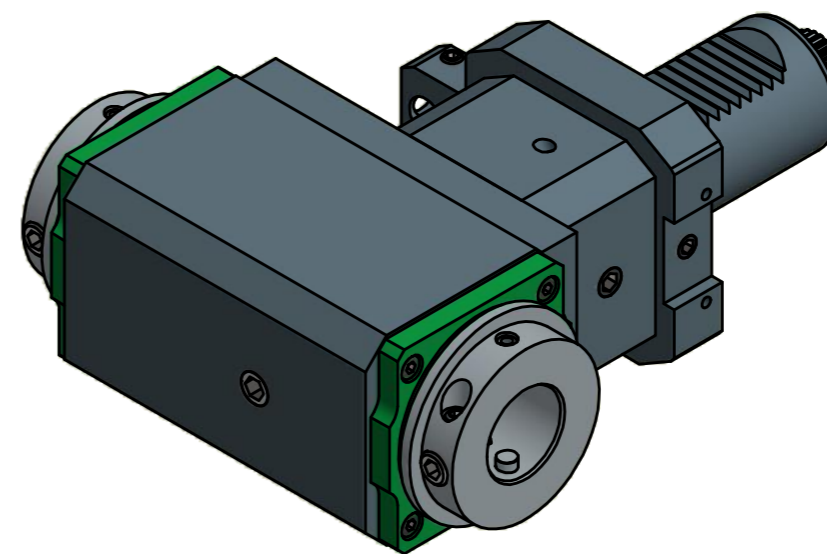

Copyright **EWS Tool Technologies**  
 Weitergabe und Vervielfaeltigung dieser Unterlage,  
 Verwertung und Mitteilung ihres Inhalts nicht  
 gestattet, soweit nicht ausdruercklich zugestanden.  
 Zuwiderhandlungen verpflichten zu Schadenersatz.

Bemerkung - Note Nicht ohne Kuehlmittel betreiben! Not for use without coolant-fluid! <b>Schutzrecht angemeldet</b> <b>Trademark right applied</b>	Technische Daten - technical data Weight = 7.097 [kg] Torque max. (M1/M2) = 25 / 25   25 [Nm] Speed max. (n1/n2) = 6000 / 6000   6000 [1/min] Gear ratio (i)=n1:n2 = 1:1   1:1 Pressure (pmax) = 25 [bar]
--	--

Benennung - Title  
**Radial Bohr und Fräskopf**  
*Radial drilling and milling head*

<b>EWS</b> <small>EWS Weigle GmbH &amp; Co. KG          Maybachstr. 1          D-73066 Uhlingen          www.ews-tools.de</small>	Technische Aenderungen vorbehalten! Subject to technical modifications! IDENT: DEWS107394	REV: -/A MNR:
	Nr. - No. <b>60.40V3DCTXRLIK-BG30</b>	<b>135258</b>

