

Spannzange / collet ER40 DIN6499  
Spannbereich / clamping range: 3,0 - 26,0

Gewindebohrzange / tapping collet  
ET-1-40 M6-M16

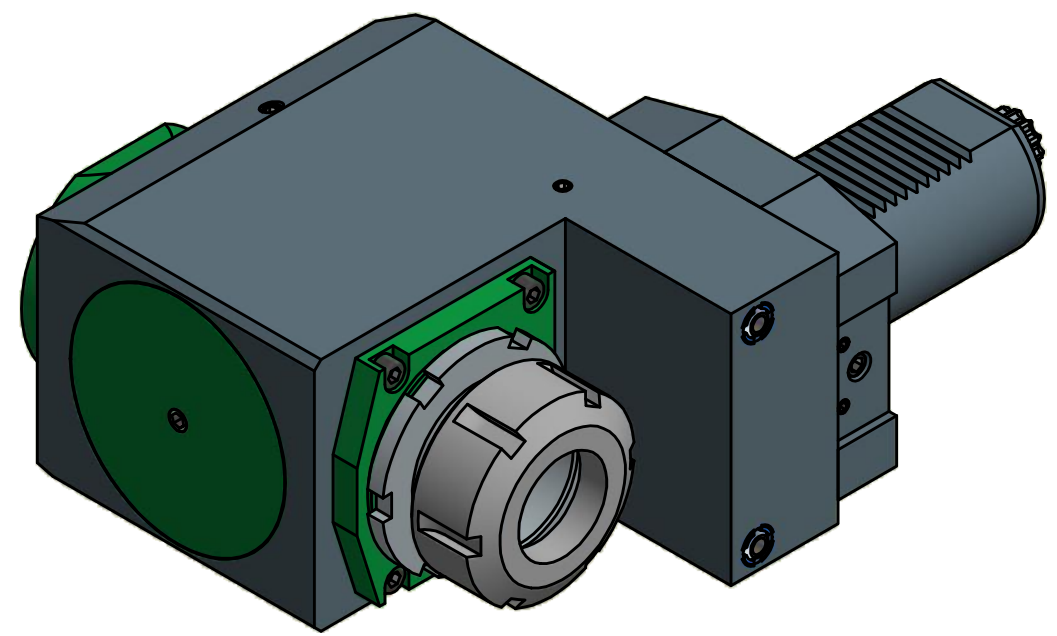
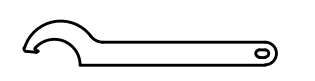
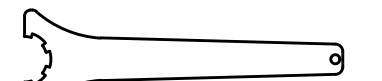

  
Hakenschlüssel  
mit Nase  
Hook wrench with  
nose end  
DIN1810 A 68x75

  
Spannzangenschlüssel  
Clamping wrench  
240

Copyright **EWS Tool Technologies**  
Weitergabe und Vervielfältigung dieser Unterlage,  
Verwertung und Mitteilung ihres Inhalts nicht  
gestattet, soweit nicht ausdrücklich zugestanden.  
Zuwerhandlungen verpflichten zu Schadenersatz.

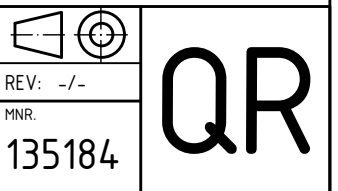
Bemerkung - Note	Technische Daten - technical data <b>Weight</b> = 12.197 [kg] <b>Torque max. (M1/M2)</b> = 100 / 50 [Nm] <b>Speed max. (n1/n2)</b> = 4000 / 8000 [1/min] <b>Gear ratio (i)=n1:n2</b> = 1:2	Benennung - Title <b>Radial Bohr und Fräskopf, zurückges</b> <b>Radial drill. and mill. head offset</b>	 EWS Weigle GmbH & Co. KG Maybachstr. 1 D-73066 Ulm/ingen www.ews-tool.de Nr. - No. <b>80.504.054.82R11</b>	Technische Änderungen vorbehalten! Subject to technical modifications! IDENT: D-EWS-002650 MNR. <b>135184</b>	
------------------	--	---	--	---	---