

Spannzange / collet ER25 DIN6499  
 Spannereich / clamping range: 1,0 - 16,0

Gewindebohrzange / tapping collet  
 ET-1-25 M3-M12

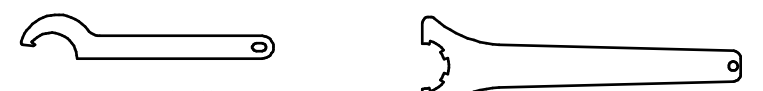
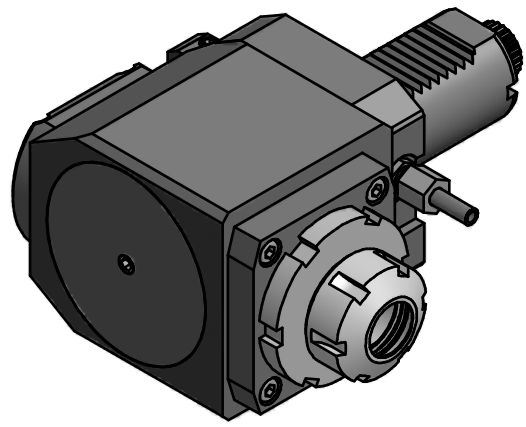

Hakenschlüssel  
 mit Nase  
 Hook wrench with  
 nose end  
 DIN1810 A 58x62

Spannzangenschlüssel  
 Clamping wrench  
 225

Copyright **EWS Tool Technologies**  
 Weitergabe und Vervielfaeltigung dieser Unterlage,  
 Verwertung und Mitteilung ihres Inhalts nicht  
 gestattet, soweit nicht ausdrecklich zugestanden.  
 Zuwiderhandlungen verpflichten zu Schadenersatz.

Bemerkung - Note	Technische Daten - technical data M1 / M2 = 45 / 15 Nm n1 / n2 = 5000 / 15000 1/min i (N1:N2) = 1:3	Benennung - Title <b>Radial Bohr und Fräskopf</b> <i>Radial drilling and milling head</i>	<table border="1"> <tr> <th>name</th> <th>date</th> </tr> <tr> <td>M. Simoniello</td> <td>12.02.2013</td> </tr> </table>	name	date	M. Simoniello	12.02.2013	Technische Aenderungen vorbehalten! Subject to technical modifications! Nr. <b>60.4025KCTXRI13</b> MNR: 164608 IDENT: D-EWS-132047 - Blatt - page 1 (1)
name	date							
M. Simoniello	12.02.2013							