

Spannzange / collet ER32 DIN6499  
 Spannereich / clamping range: 2,0 - 20,0

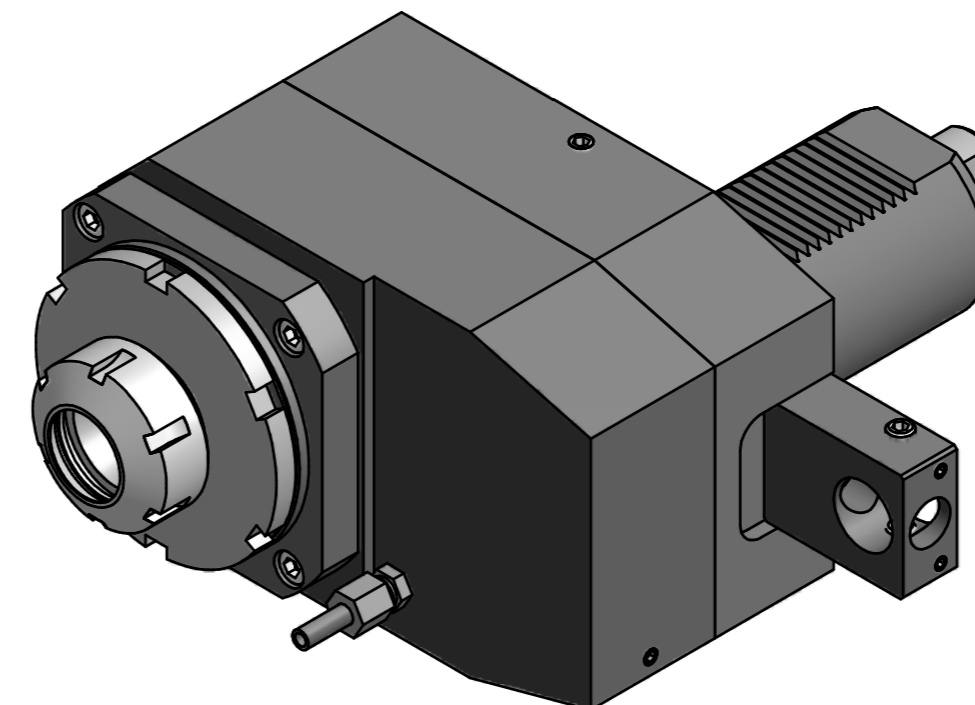

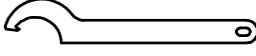
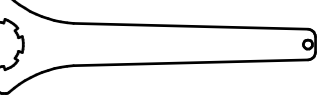
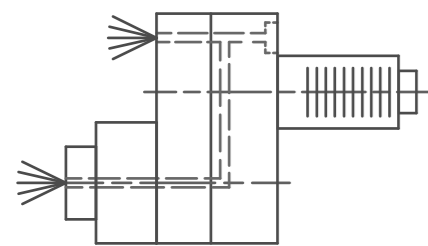

 Hakenschlüssel  
 mit Nase  
 Hook wrench with  
 nose end  
 DIN1810 A 80x90

 Spannzangenschlüssel  
 Clamping wrench  
 232



Innen- und Aussenkuehlung / Inside and outside coolant supply  
 Kein Trockenlauf / No dry run  
 Kuehlmittelfiltrierung+50µ / coolant filtration+50µ

Copyright **EWS Tool Technologies**  
 Weitergabe und Vervielfaeltigung dieser Unterlage,  
 Verwertung und Mitteilung ihres Inhalts nicht  
 gestattet, soweit nicht ausdrecklich zugestanden.  
 Zuwiderhandlungen verpflichten zu Schadenersatz.

Bemerkung - Note Nicht ohne Kuehlmittel betreiben! Not for use without coolant-fluid!	Technische Daten - technical data Weight = 16,088 [kg] Torque max. (M1/M2) = 100 / 50 [Nm] Speed max. (n1/n2) = 4000 / 8000 [1/min] Gear ratio (i)=n1:n2 = 1:2 Pressure (pmax) = 70 [bar]	Benennung - Title <b>Axial Bohr u. Fräskopf achsversetzt</b> <b>Ax. drill. and mill. head offset</b>	 EWS Weigle GmbH & Co. KG Maybachstr. 1 D-73066 Uhlringen www.ews-tool.de	Technische Aenderungen vorbehalten! Subject to technical modifications! IDENT: D-EWS-203371 Nr. - No. 50.60321809LIK1 MNR. 164524	
---	--	--	---	---	---