

Spannzange / collet ER32 DIN6499
 Spannbereich / clamping range: 2,0 - 20,0

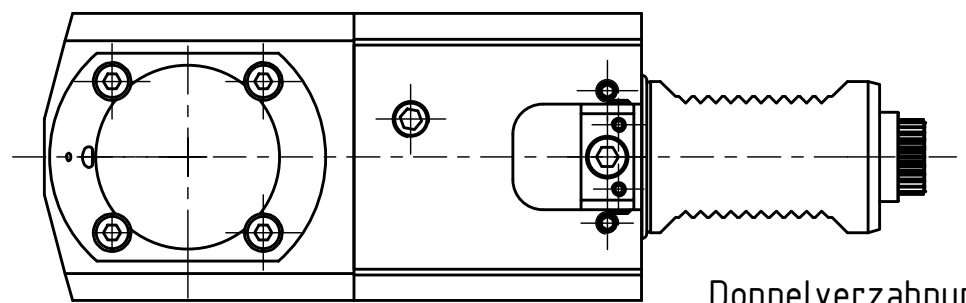

Doppelverzahnung Lizenz Traub
 double tooth system licence Traub

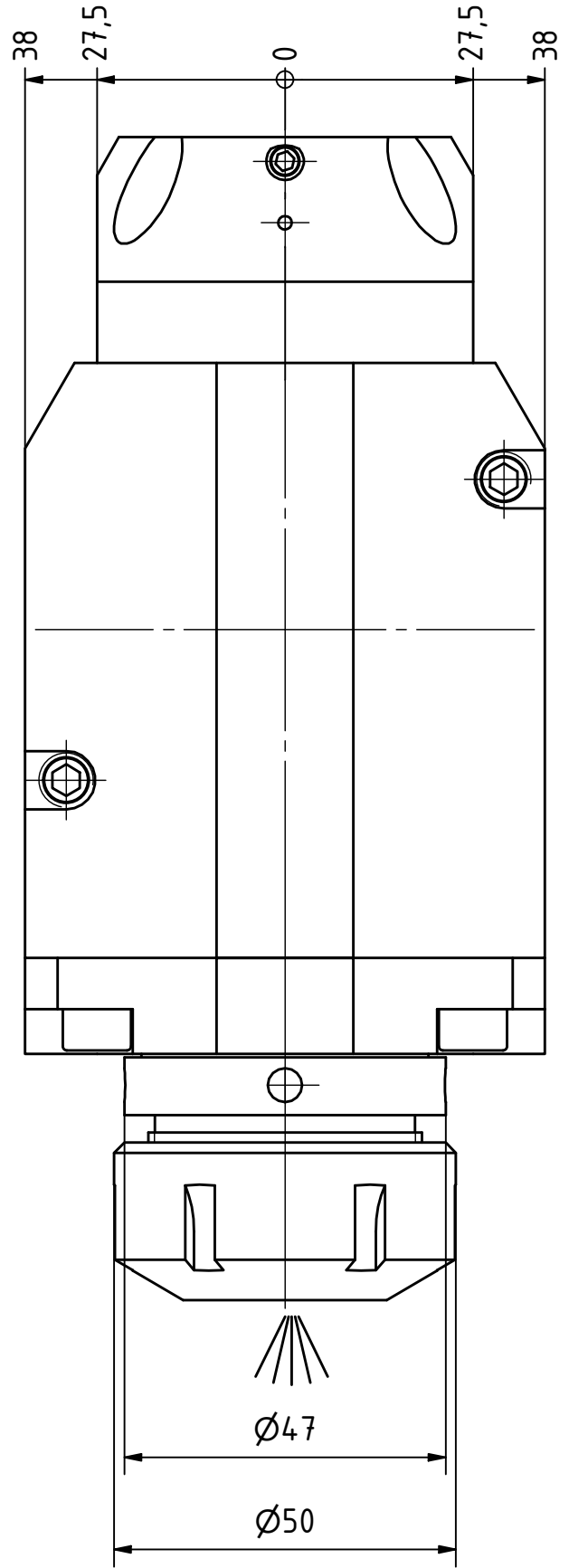
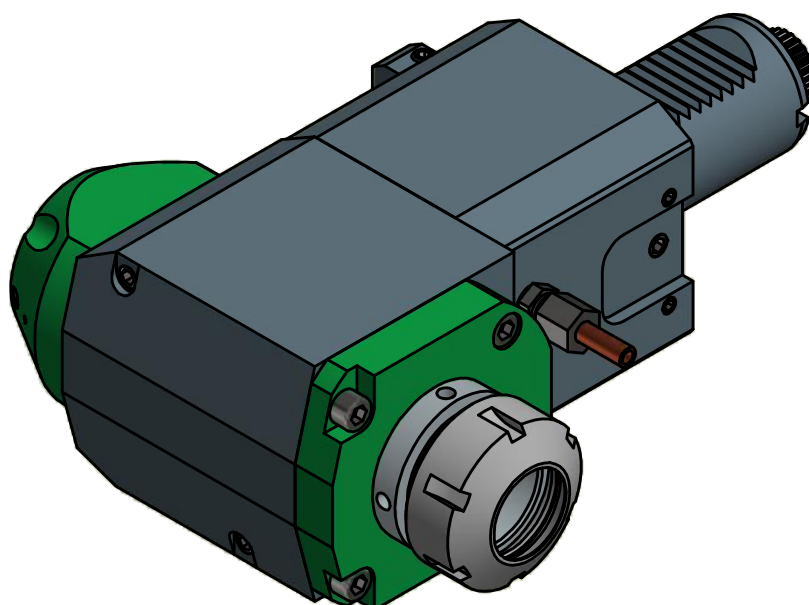
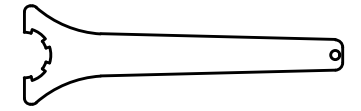

Spannzangenschlüssel
 Clamping wrench
 232

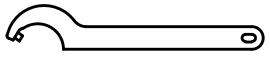

Hakenschlüssel
 mit Zapfen
 Hook wrench
 with fixed pin
 DIN1810 B 45x50

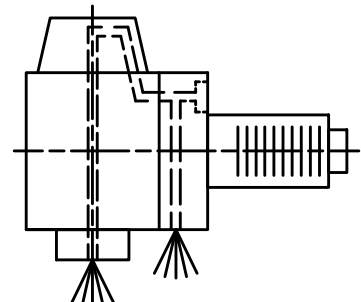

Innen- und Aussenkuehlung / Inside and outside coolant supply
 Kein Trockenlauf / No dry run
 Kuehlmitelfiltrierung-50µ / coolant filtration-50µ

Copyright **EWS Tool Technologies**
 Weitergabe und Vervielfaeltigung dieser Unterlage,
 Verwertung und Mitteilung ihres Inhalts nicht
 gestattet, soweit nicht ausdrecklich zugestanden.
 Zuwiderhandlungen verpflichten zu Schadenersatz.

Bemerkung - Note Nicht ohne Kuehlmitel betreiben! Not for use without coolant-fluid! mit Kegelrollenlager with taper roller bearing(s)	Technische Daten - technical data Weight = 8.093 [kg] Torque max. (M1/M2) = 50 / 50 [Nm] Speed max. (n1/n2) = 6000 / 6000 [1/min] Gear ratio (i)=n1:n2 = 1:1 Pressure (pmax) = 70 [bar]
--	--

Benennung - Title
Radial Bohr und Fräskopf
 Radial drilling and milling head

EWS <small>EWS Weigle GmbH & Co. KG Maybachstr. 1 D-73066 Uhlingen www.ews-tools.de</small>	Technische Aenderungen vorbehalten! Subject to technical modifications! IDENT: D-EWS-138732	
	Nr. - No. 60.4032KRLCTXRLIK	REV: -/- MNR. 166907

