

Spannzange / collet ER40 DIN6499  
Spannbereich / clamping range: 3,0 - 26,0

Gewindebohrzange / tapping collet  
ET-1-40 M6-M16

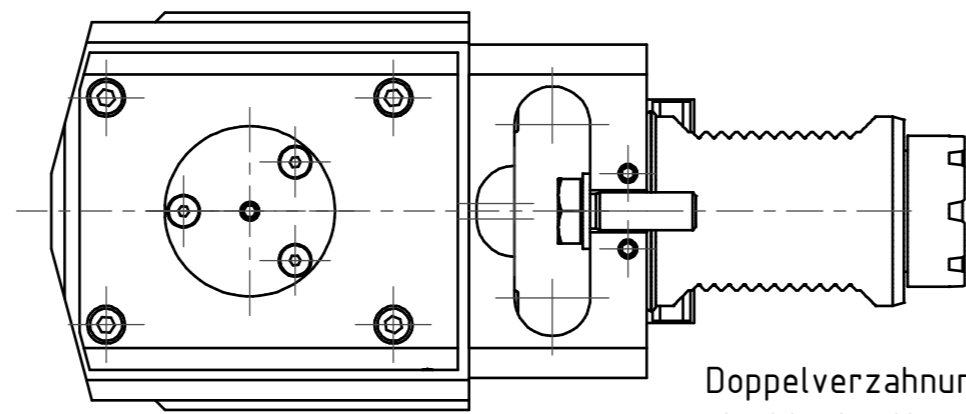

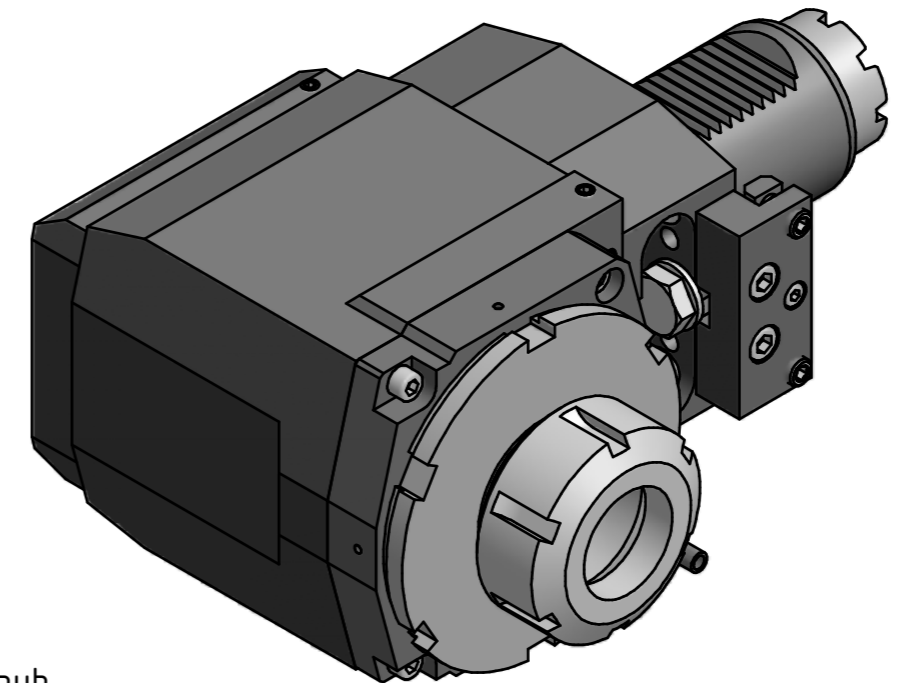

Doppelverzahnung Lizenz Traub  
double tooth system licence Traub



Hakenschlüssel  
mit Nase  
Hook wrench with  
nose end  
DIN1810 A 110x115

Spannzangenschlüssel  
Clamping wrench  
240

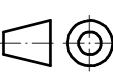
Copyright **EWS Tool Technologies**  
Weitergabe und Vervielfältigung dieser Unterlage,  
Verwertung und Mitteilung ihres Inhalts nicht  
gestattet, soweit nicht ausdrücklich zugestanden.  
Zuwendungen verpflichten zu Schadenersatz.

Benennung - Note mit Kegelrollenlager with taper roller bearing(s)	Technische Daten - technical data M <sub>1</sub> / M <sub>2</sub> = 80 / 160 Nm n <sub>1</sub> / n <sub>2</sub> = 4000 / 2000 1/min i (N <sub>1</sub> :N <sub>2</sub> ) = 2:1	Benennung - Title <b>Radial Bohr und Fräskopf</b> <i>Radial drilling and milling head</i>	name	date	Technische Änderungen vorbehalten! Subject to technical modifications!	 DIN A2
			drawing	Theiss		
			 Weigete GmbH & Co. KG Maybachstr. 1 D-73066 Ulmringen Tel. +49(0)7161/93040-10		Nr. <b>60.5040KRTOEMRLI2X105</b>	
			File: D-EWS-129158-.idw		Blatt - page 1 (1)	