

Spannzange / collet ER40 DIN6499
 Spannbereich / clamping range: 3,0 - 26,0

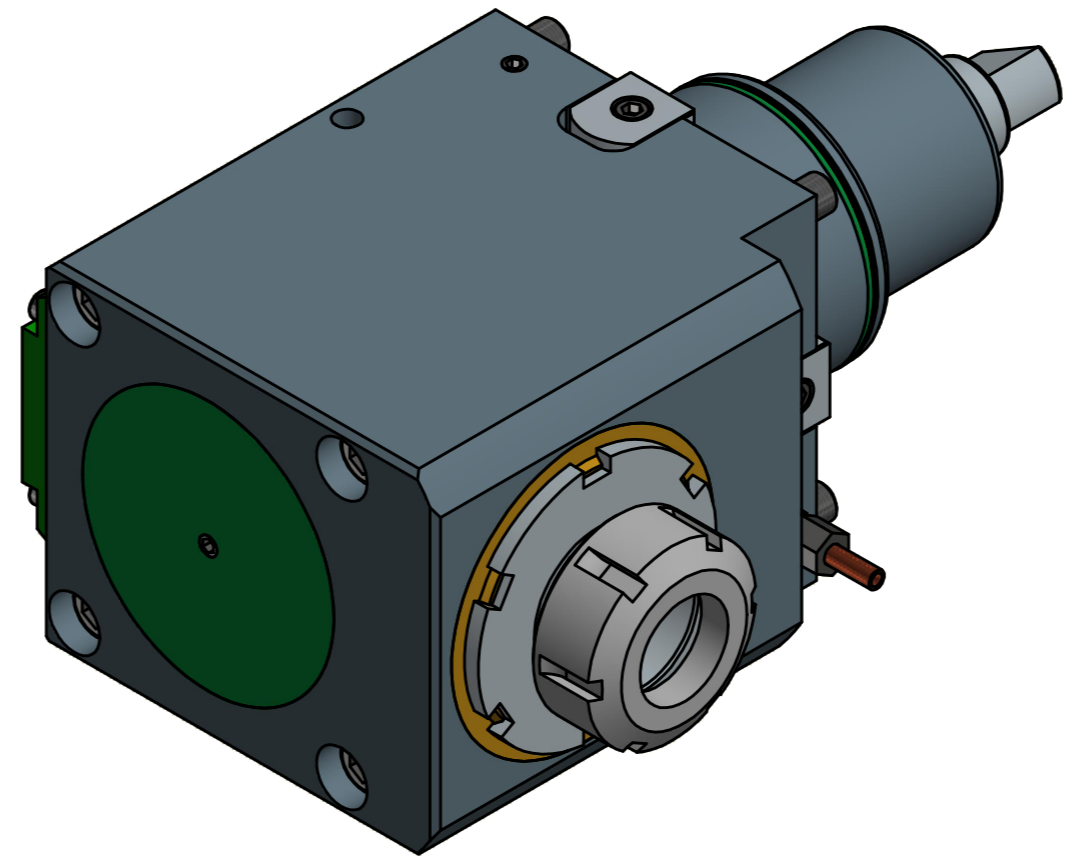

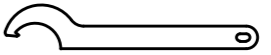
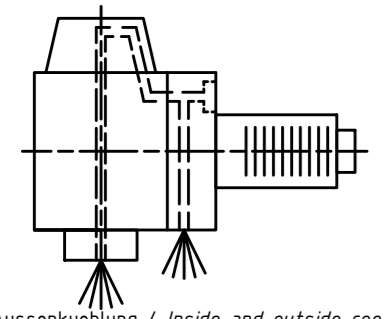

 Hakenschlüssel
 mit Nase
 Hook wrench with
 nose end
 DIN1810 A 80x90

 Spannzangenschlüssel
 Clamping wrench
 240



Innen- und Aussenkuehlung / Inside and outside coolant supply
 Kein Trockenlauf / No dry run
 Kuehlmittelfiltrierung-50µ / coolant filtration-50µ

Copyright **EWS Tool Technologies**
 Weitergabe und Vervielfaeltigung dieser Unterlage,
 Verwertung und Mitteilung ihres Inhalts nicht
 gestattet, soweit nicht ausdrecklich zugestanden.
 Zuwiderhandlungen verpflichten zu Schadenersatz.

Bemerkung - Note Nicht ohne Kuehlmittel betreiben! Not for use without coolant-fluid!	Technische Daten - technical data Weight = 23.439 [kg] Torque max. (M1/M2) = 100 / 100 [Nm] Speed max. (n1/n2) = 4000 / 4000 [1/min] Gear ratio (i)=n1:n2 = 1:1 Pressure (pmax) = 70 [bar]	Benennung - Title Radial Bohr und Fräskopf Radial drilling and milling head	 EWS Weigle GmbH & Co. KG Maybachstr. 1 D-73066 Uhlingen www.ews-tools.de Nr. - No. 60.854.01809IKGLX110	Technische Aenderungen vorbehalten! Subject to technical modifications! IDENT: DEWS132906 MNR. REV: -/B 165236	 QR
---	---	---	--	--	---