

n2 Spannzange / Collet ER16 DIN6499
Spannbereich / Clamping range: 1,0 - 10,0

n1

Hakenschlüssel
mit Nase
Hook wrench with
nose end
DIN1810 A 34x36

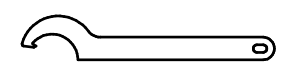
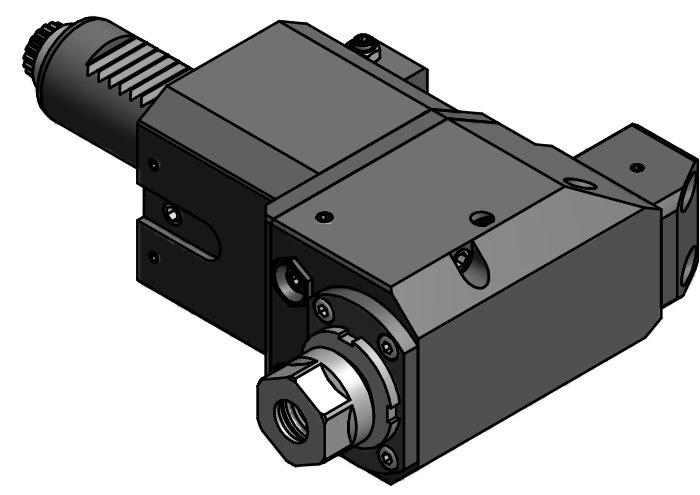

Copyright **EWS Tool Technologies**
Weitergabe und Vervielfaeltigung dieser Unterlage,
Verwertung und Mitteilung ihres Inhalts nicht
gestattet, soweit nicht ausdruercklich zugestanden.
Zuwiderhandlungen verpflichten zu Schadenersatz.

Innen- und Aussenkuehlung / Inside and outside coolant supply
Kein Trockenlauf / No dry run
Kuehlmittelfiltrierung < 50µ / coolant filtration < 50µ

Bemerkung - Note Nicht ohne Kuehlmittel betreiben! Not for use without coolant-fluid!	Technische Daten - technical data	Benennung - Title Radial Bohr und Fräskopf <i>Radial drilling and milling head</i>	name	date	Technische Aenderungen vorbehalten! Subject to technical modifications!	
	M1 / M2 = 15 / 5 Nm n1 / n2 = 6000 / 18000 1/min i (N1:N2) = 1:3 pmax = 70 bar		drawing	Theiss		
			EWS Tool Technologies Weigele GmbH & Co. KG Maybachstr. 1 D-73066 Uehingen Tel. +49(0)7161/93040-10		File: D-EWS-159650-.idw	Blatt - page 1 (1)