

Innen- und Aussenkuehlung / Inside and outside coolant supply
 Kein Trockenlauf / No dry run
 Kuehlmittelfiltrierung <math>< 50\mu</math> / coolant filtration <math>< 50\mu</math>

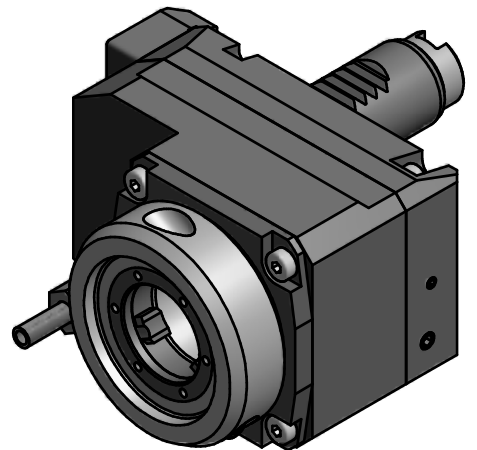

Copyright **EWS Tool Technologies**
 Weitergabe und Vervielfaeltigung dieser Unterlage,
 Verwertung und Mitteilung ihres Inhalts nicht
 gestattet, soweit nicht ausdruercklich zugestanden.
 Zuwiderhandlungen verpflichten zu Schadenersatz.

Bemerkung - Note Nicht ohne Kuehlmittel betreiben! Not for use without coolant-fluid!	Technische Daten - technical data $M1 / M2 = 25 / 25 \text{ Nm}$ $n1 / n2 = 8000 / 8000 \text{ 1/min}$ $i (N1:N2) = 1:1$ $p_{max} = 70 \text{ bar}$	Benennung - Title Axial Bohr u. Fräskopf achsversetzt Ax. drill. and mill. head offset	<table border="1"> <thead> <tr> <th>name</th> <th>date</th> </tr> </thead> <tbody> <tr> <td>Theiss</td> <td>13.08.2013</td> </tr> </tbody> </table>	name	date	Theiss	13.08.2013	Technische Aenderungen vorbehalten! Subject to technical modifications! Nr. 50.25VX3G200RIK	DIN A3
name	date								
Theiss	13.08.2013								
MNR: 165848		IDENT: D-EWS-140592 -		Blatt - page 1 (1)					