

ABS 50
(Lizenz Komet)

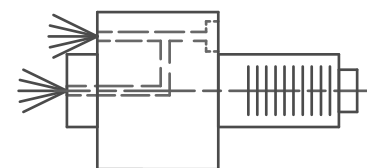
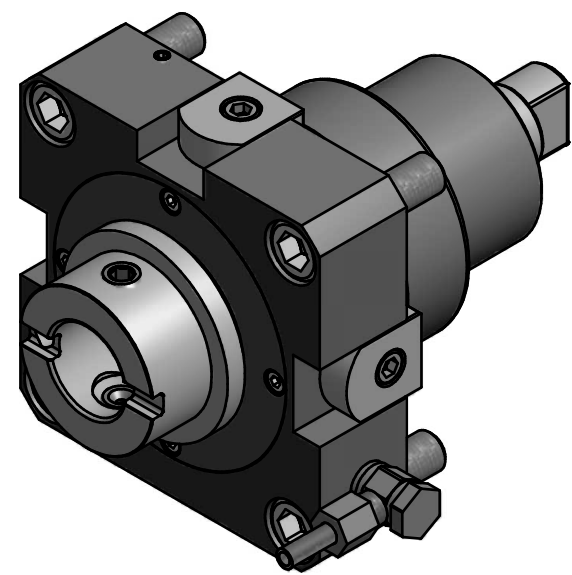
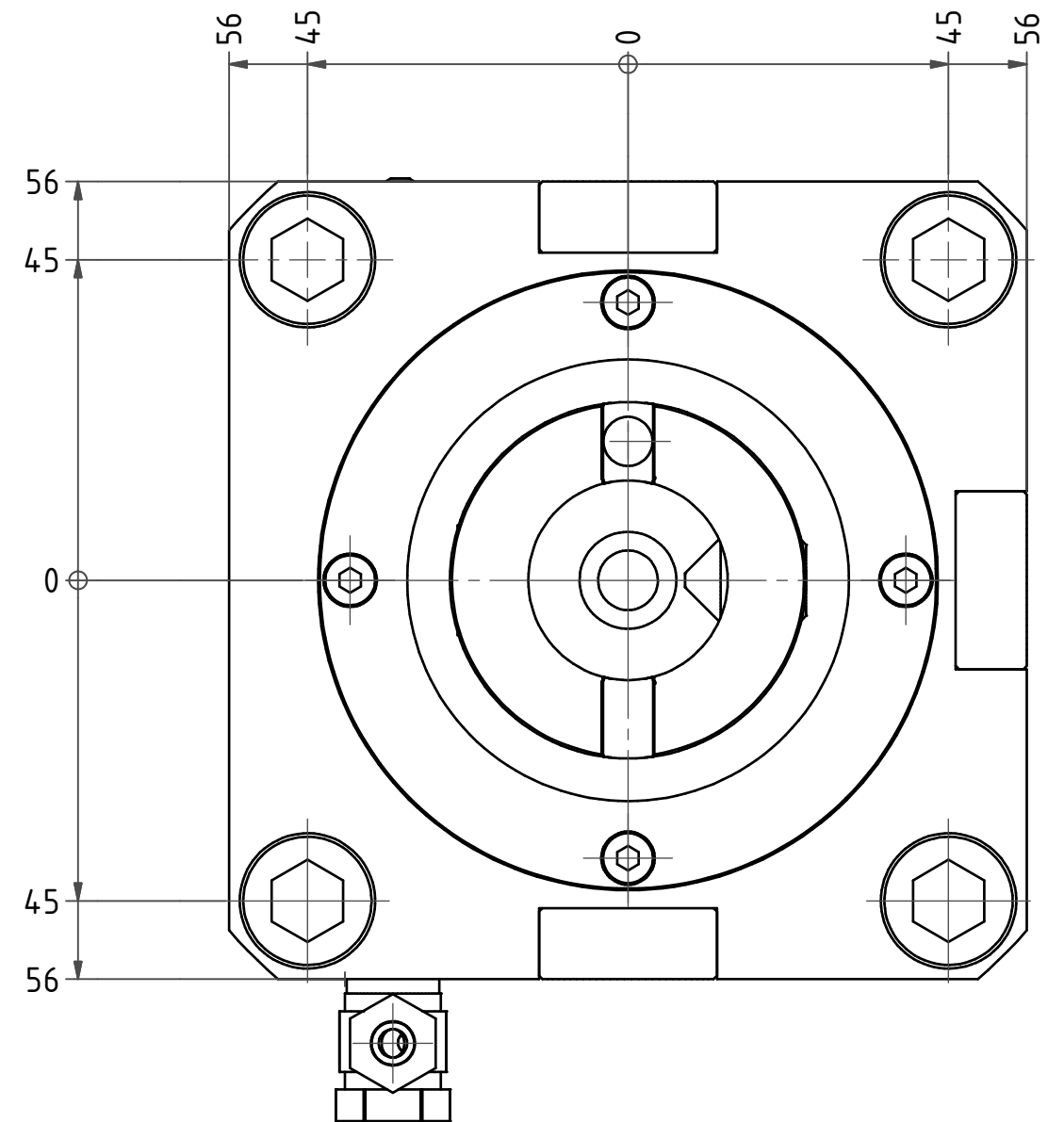

Innen- und Aussenkuehlung / Inside and outside coolant supply
Kein Trockenlauf / No dry run
Kuehlmittelfiltrierung <math>< 50\mu</math> / coolant filtration <math>< 50\mu</math>

Copyright **EWS Tool Technologies**
Weitergabe und Vervielfaeltigung dieser Unterlage,
Verwertung und Mitteilung ihres Inhalts nicht
gestattet, soweit nicht ausdruuecklich zugestanden.
Zuwiderhandlungen verpflichten zu Schadenersatz.

Bemerkung - Note
Nicht ohne Kuehlmittel betreiben!
Not for use without coolant-fluid!

Technische Daten - technical data	
Weight	= 5.247 [kg]
Torque max. (M1/M2)	= 80 / 80 [Nm]
Speed max. (n1/n2)	= 4.000 / 4.000 [1/min]
Gear ratio (i)=n1:n2	= 1:1
Pressure (pmax)	= 25 [bar]

Benennung - Title
Axial Bohr und Fräskopf
Axial drilling and milling head

EWS Tool Technologies
EWS Weigle GmbH & Co. KG
Maybachstr. 1
D-73066 Utingen
www.ews-tools.de

Nr. - No.
40.75ABS501809IK

Technische Aenderungen vorbehalten! Subject to technical modifications!	IDENT: D-EWS-047990
REV: B/-	MNR. 134947

