

Spannzange / collet ER25 DIN6499
 Spannbereich / clamping range: 1,0 - 16,0

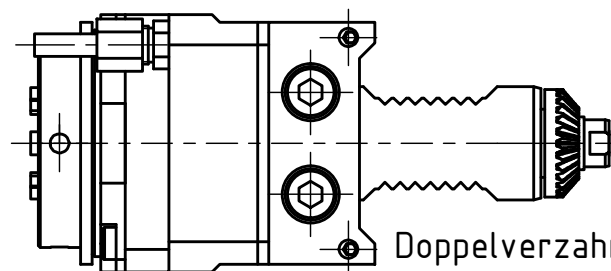

Doppelverzahnung Lizenz Traub
 double tooth system licence Traub

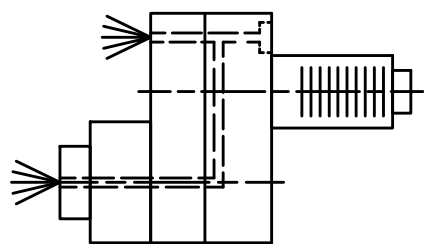
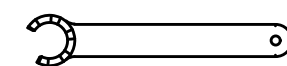
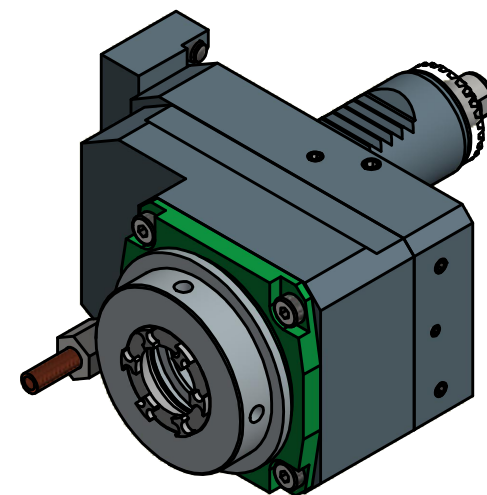

Spannzangenschlüssel für
 innenliegende Mutter
 Clamping wrench for
 internal collet
 225AX

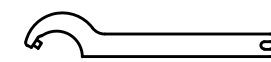

Hakenschlüssel
 mit Zapfen
 Hook wrench
 with fixed pin
 DIN1810 B 52x55

Innen- und Aussenkuehlung / Inside and outside coolant supply
 Kein Trockenlauf / No dry run
 Kuehlmittelfiltrierung < 50µ / coolant filtration < 50µ

Copyright **EWS Tool Technologies**
 Weitergabe und Vervielfaeltigung dieser Unterlage,
 Verwertung und Mitteilung ihres Inhalts nicht
 gestattet, soweit nicht ausdrecklich zugestanden.
 Zuwiderhandlungen verpflichten zu Schadenersatz.

Bemerkung - Note
 Nicht ohne Kuehlmittel betreiben!
 Not for use without coolant-fluid!

Technische Daten - technical data
 Weight = 3.274 [kg]
 Torque max. (M1/M2) = 24 / 12 [Nm]
 Speed max. (n1/n2) = 6000 / 12000 [1/min]
 Gear ratio (i)=n1:n2 = 1:2
 Pressure (pmax) = 70 [bar]

Benennung - Title
Axial Bohr u. Fräskopf achsversetzt
Ax. drill. and mill. head offset

EWS Tool Technologies
 EWS Weigle GmbH & Co. KG
 Maybachstr. 1
 D-73066 UHINGEN
 www.ews-tools.de
 Nr. - No.
50.3025TNC65RLIK11M

Technische Aenderungen vorbehalten!
 Subject to technical modifications!
 IDENT: DEWS104164
 MNR.
165153

REV: -/A

