

Spannzange / collet ER25 DIN6499  
 Spannungsbereich / clamping range: 1,0 - 16,0

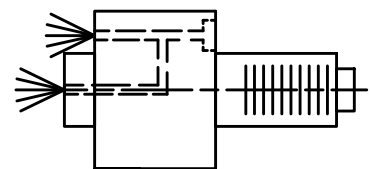

Innen- und Aussenkuehlung / Inside and outside coolant supply  
 Kuehlmittelfiltrierung-50µ / coolant filtration<50µ

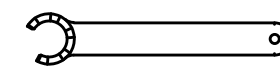
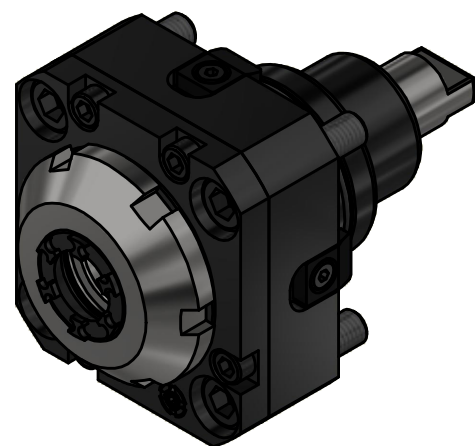

Spannzangenschlüssel für  
 innenliegende Mutter  
 Clamping wrench for  
 internal collet  
 225AX

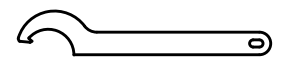

Hakenschlüssel  
 mit Nase  
 Hook wrench with  
 nose end  
 DIN1810 A 68x75

Copyright **EWS Tool Technologies**  
 Weitergabe und Vervielfaeltigung dieser Unterlage,  
 Verwertung und Mitteilung ihres Inhalts nicht  
 gestattet, soweit nicht ausdrecklich zugestanden.  
 Zuwiderhandlungen verpflichten zu Schadenersatz.

Bemerkung - Note  
 Für Trockenlauf geeignet!  
 Use without coolant fluid allowed!

Technische Daten - technical data  
 Weight = 2.943 [kg]  
 Torque max. (M1/M2) = 50 / 50 [Nm]  
 Speed max. (n1/n2) = 6000 / 6000 [1/min]  
 Gear ratio (i)=n1:n2 = 1:1  
 Pressure (pmax) = 70 [bar]

Benennung - Title  
**Axial Bohr und Fräskopf**  
**Axial drilling and milling head**



Nr. - No.  
**40.5525VL2IKDIM**

Technische Aenderungen vorbehalten!  
 Subject to technical modifications!

IDENT: DEWS022648

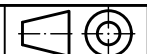

REV: -/B

MNR.  
**164294**

