

Innen- und Aussenkuehlung  
Inside and outside coolant supply

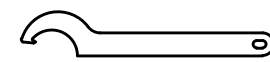

Hakenschlüssel  
mit Nase  
Hook wrench with  
nose end  
DIN1810 A 52x55

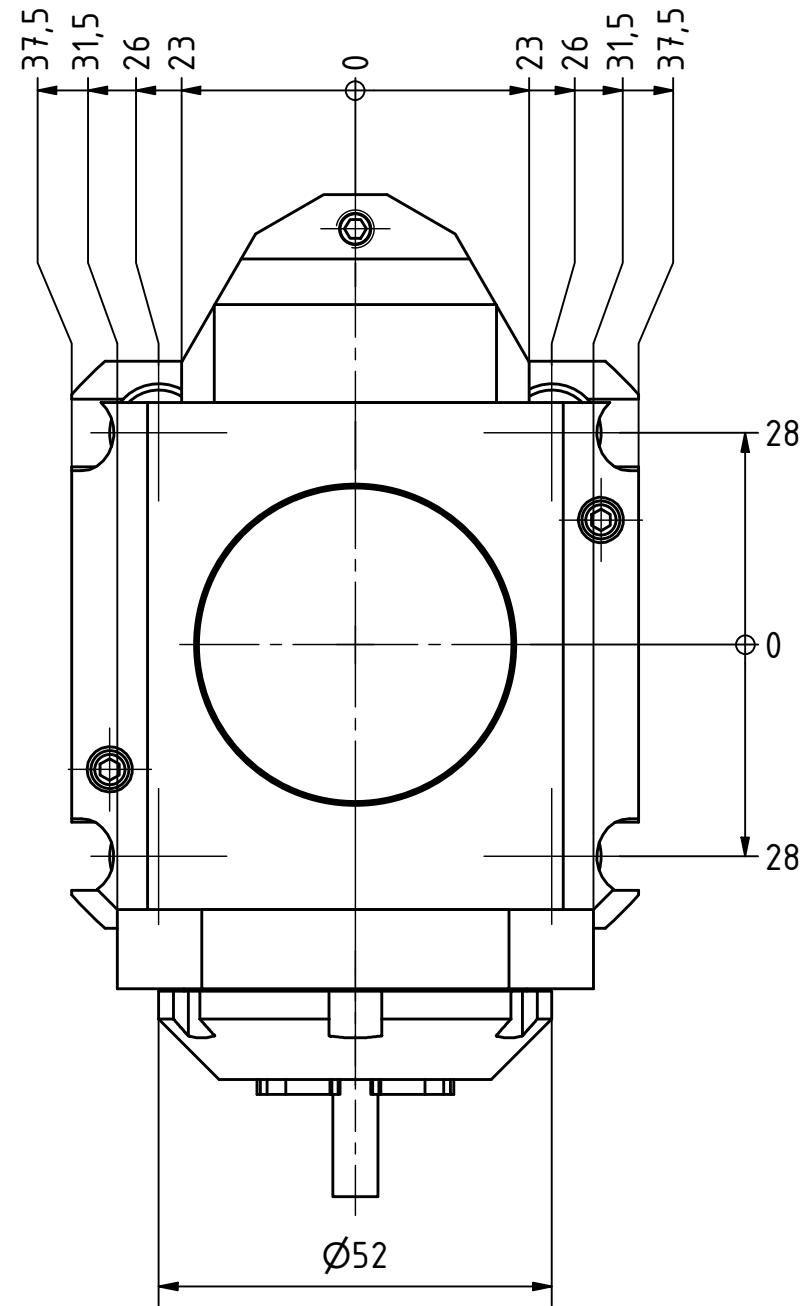
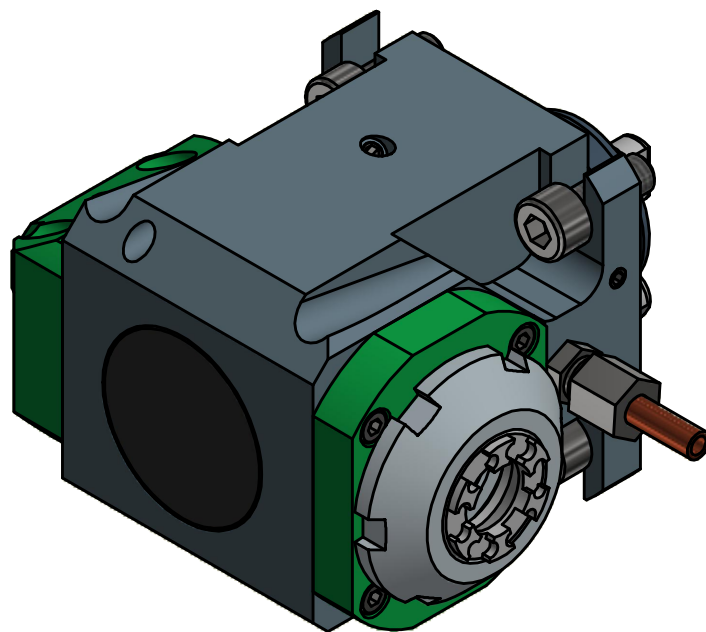
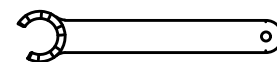

Spannzangenschlüssel für  
innenliegende Mutter  
Clamping wrench for  
internal collet  
220AX

Spannzange / collet ER20 DIN6499  
Spannbereich / clamping range: 1,0 - 13,0

Copyright **EWS Tool Technologies**  
Weitergabe und Vervielfaeltigung dieser Unterlage,  
Verwertung und Mitteilung ihres Inhalts nicht  
gestattet, soweit nicht ausdrecklich zugestanden.  
Zuwiderhandlungen verpflichten zu Schadenersatz.

Bemerkung - Note  
Nicht ohne Kuehlmittel betreiben!  
Not for use without coolant-fluid!

Technische Daten - technical data  
Weight = 3.367 [kg]  
Torque max. (M1/M2) = 16 / 16 [Nm]  
Speed max. (n1/n2) = 6000 / 6000 [1/min]  
Gear ratio (i)=n1:n2 = 1:1  
Pressure (pmax) = 70 [bar]

Benennung - Title  
**Radial Bohr und Fräskopf**  
**Radial drilling and milling head**



Nr. - No.  
60.3820BNA1809IKIM

Technische Aenderungen vorbehalten!  
Subject to technical modifications!  
IDENT: DEWS135296

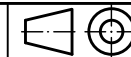

REV: -/C

MNR.  
162288

