

Doppelverzahnung Lizenz Traub
 double tooth system licence Traub

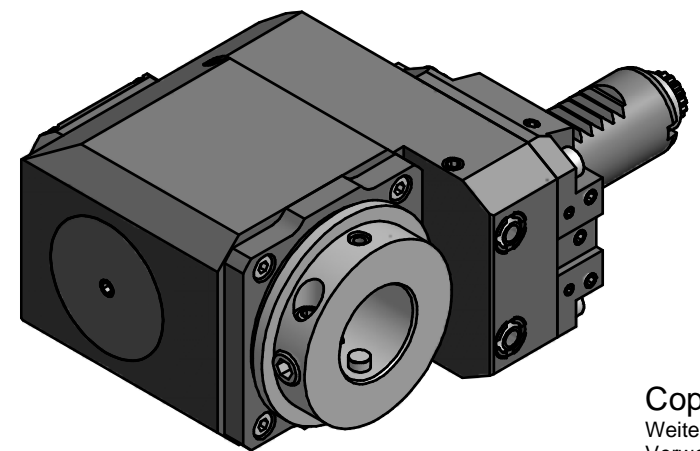
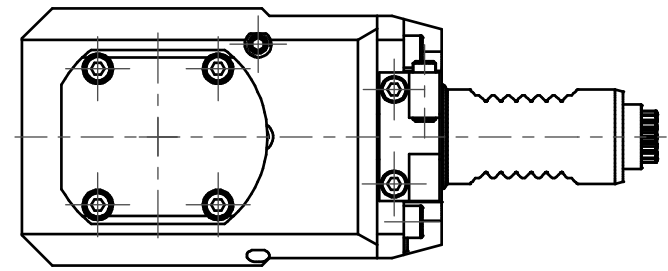

Copyright **EWS Tool Technologies**
 Weitergabe und Vervielfaeltigung dieser Unterlage,
 Verwertung und Mitteilung ihres Inhalts nicht
 gestattet, soweit nicht ausdrecklich zugestanden.
 Zuwiderhandlungen verpflichten zu Schadenersatz.

Bemerkung - Note	Technische Daten - technical data $M_1 / M_2 = 25 / 25 \text{ Nm}$ $n_1 / n_2 = 8000 / 8000 \text{ 1/min}$ $i (N_1:N_2) = 1:1$	Benennung - Title Radial Bohr und Fräskopf. zurückges Radial drill. and mill. head offset	<table border="1"> <thead> <tr> <th>name</th> <th>date</th> </tr> </thead> <tbody> <tr> <td>Schmid</td> <td>14.07.2010</td> </tr> </tbody> </table>	name	date	Schmid	14.07.2010	Technische Aenderungen vorbehalten! Subject to technical modifications! Nr. 80.25V3L5480RLF	
name	date								
Schmid	14.07.2010								
			EWS Weigle GmbH & Co. KG Maybachstr. 1 D-73066 Uhingen Tel. +49(0)7161/93040-100	MNR: 133995 IDENT: D-EWS-091241 A	Blatt - page 1 (1)				