

min. 33
max. 36,5
38

Spannzange / *collet* ER25 DIN6499
Spannbereich / *clamping range*: 1,0 - 16,0

Gewindebohrzange / *tapping collet*
ET-1-25 M3-M12

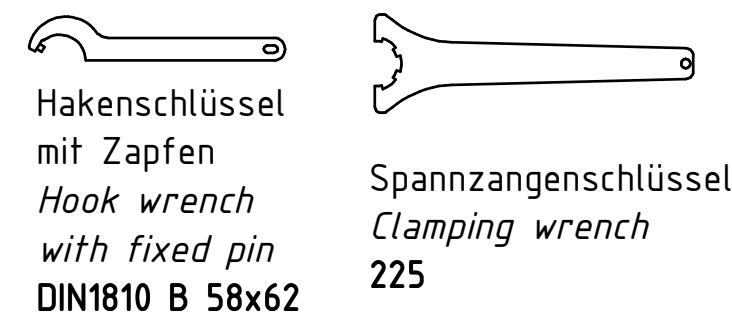
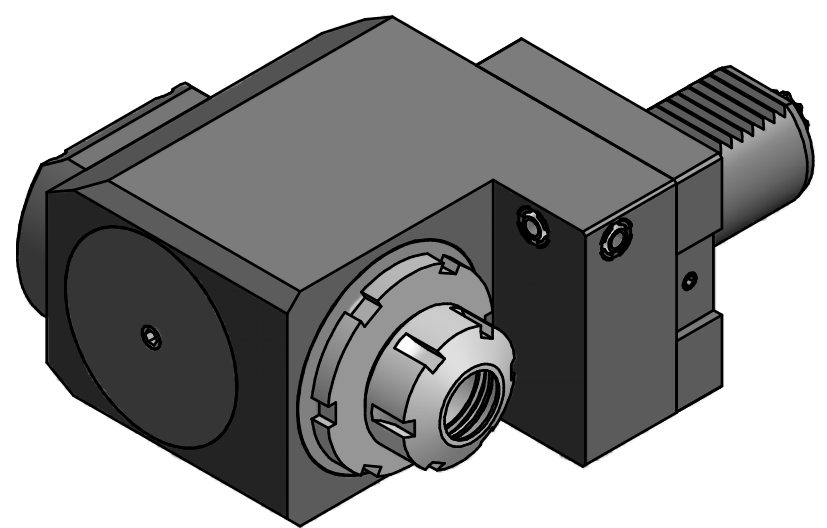

Copyright **EWS Tool Technologies**
Weitergabe und Vervielfaeltigung dieser Unterlage, Verwertung und Mitteilung ihres Inhalts nicht gestattet, soweit nicht ausdrecklich zugestanden. Zuwiderhandlungen verpflichten zu Schadenersatz.

Bemerkung - <i>Note</i> 	Technische Daten - <i>technical data</i> M1 / M2 = 50 / 25 Nm n1 / n2 = 6000 / 12000 1/min i (N1:N2) = 1:2	Benennung - <i>Title</i> Radial Bohr und Fräskopf. zurückges Radial drill. and mill. head offset	<table border="1"> <tr> <th>name</th> <th>date</th> </tr> <tr> <td>Schmid</td> <td>25.09.2013</td> </tr> </table>	name	date	Schmid	25.09.2013	Technische Aenderungen vorbehalten! <i>Subject to technical modifications!</i> Nr. 80.40255482RI1 MNR: 133552 IDENT: D-EWS-143592 - Blatt - page 1 (1)
name	date							
Schmid	25.09.2013							

