

Innen- und Aussenkuehlung / Inside and outside coolant supply
 Kein Trockenlauf / No dry run
 Kuehlmittelfiltrierung+50µ / coolant filtration+50µ

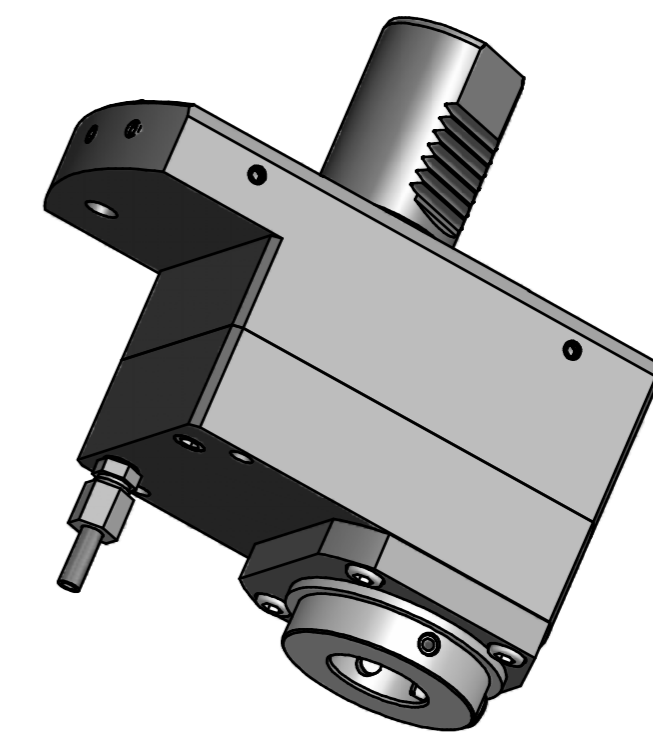

Copyright **EWS Tool Technologies**
 Weitergabe und Vervielfaeltigung dieser Unterlage,
 Verwertung und Mitteilung ihres Inhalts nicht
 gestattet, soweit nicht ausdrecklich zugestanden.
 Zuwiderhandlungen verpflichten zu Schadenersatz.

Bemerkung - Note Nicht ohne Kuehlmittel betreiben! Not for use without coolant-fluid!	Technische Daten - technical data M1 / M2 = 50 /25 Nm n1 / n2 = 6000 /12000 1/min i (N1:N2) = 1:2 Pmax = 70 bar	Benennung - Title Axial Bohr u. Fräskopf achsversetzt Ax. drill. and mill. head offset	name date 15.03.2007	Technische Aenderungen vorbehalten! Subject to technical modifications! Nr. 50.40V3SQT10RIK11 File: 50.40V3SQT10IK11_OUT.idw	 DIN A2
			drawing Weigle GmbH & Co. KG Maybachstr. 1 D-73066 Uhingen Tel. +49(0)7161/93040-10		