

* Bemerkung: für die SPINNER TC77SMCY/TC110SMCY Maschine (mit Gegenspindel) sind 130mm ausreichend!
 Note: for the SPINNER TC77SMCY/TC110SMCY machine (with opposed spindle) are 130mm sufficient!

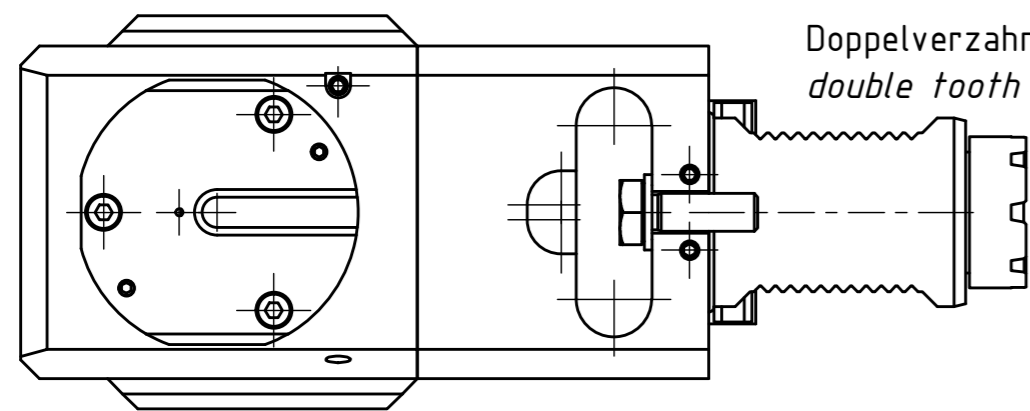

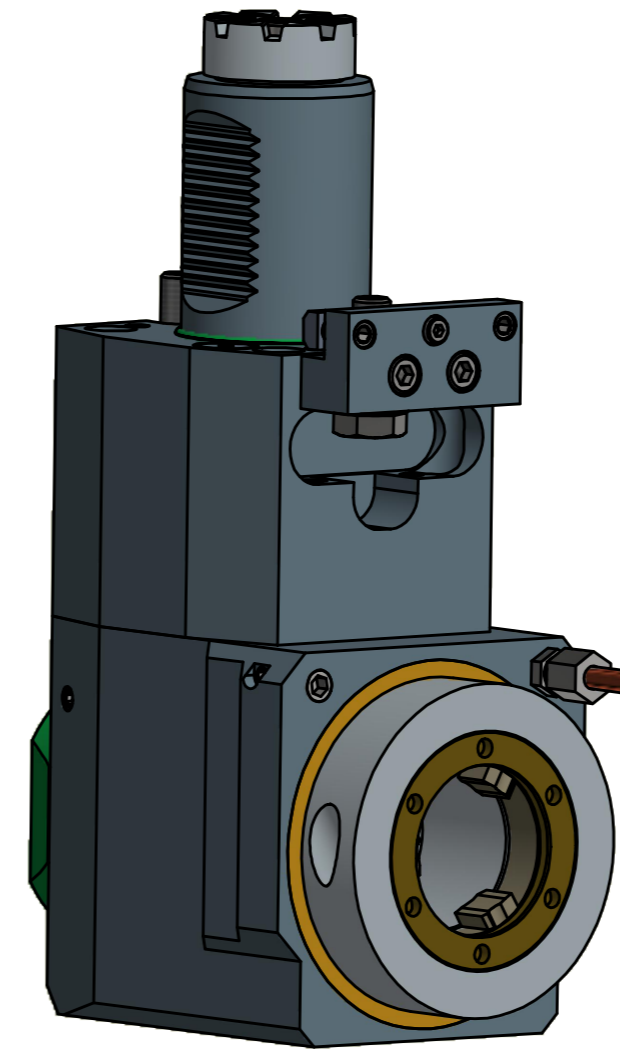

Doppelverzahnung Lizenz Traub
 double tooth system licence Traub

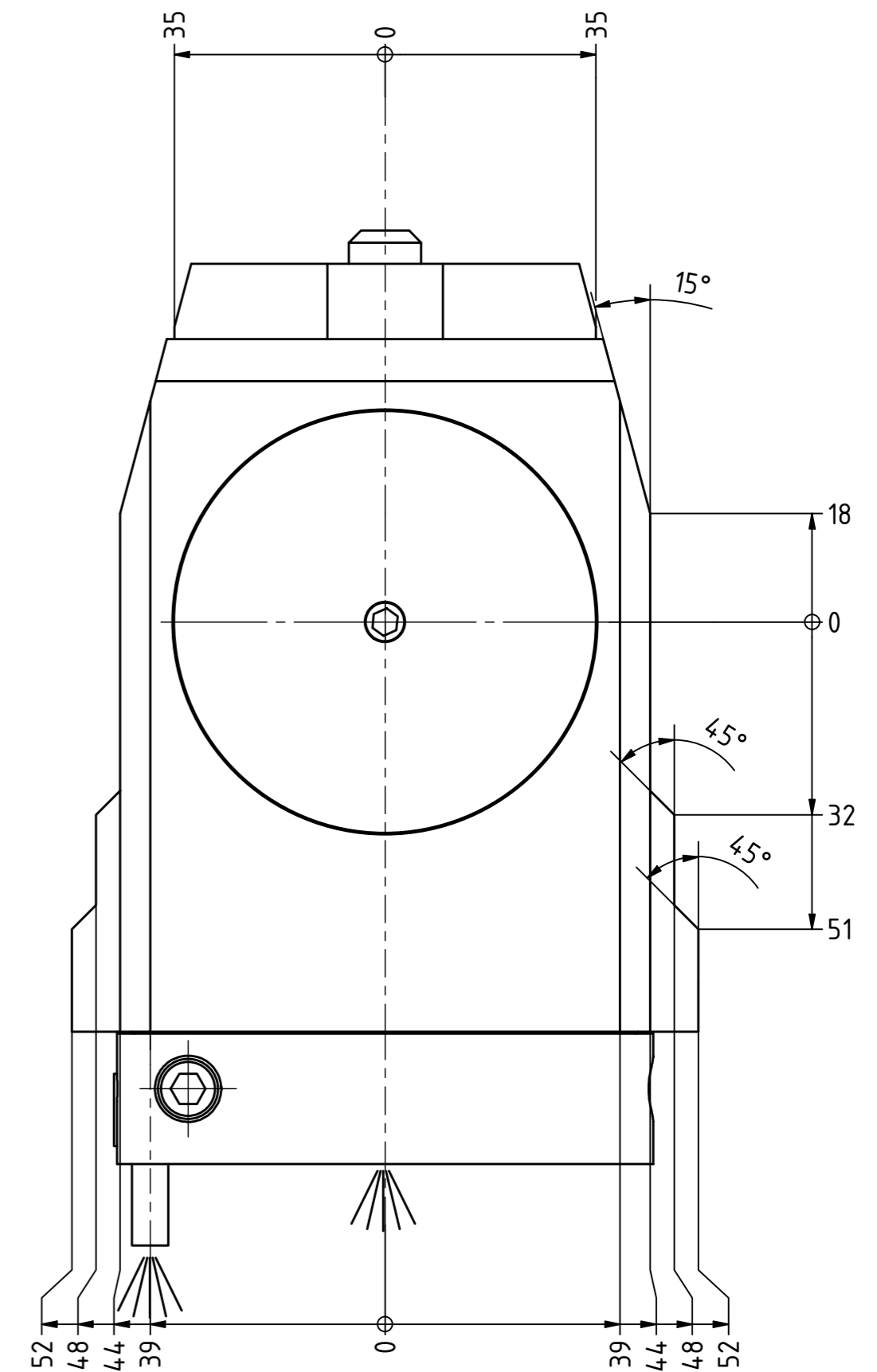
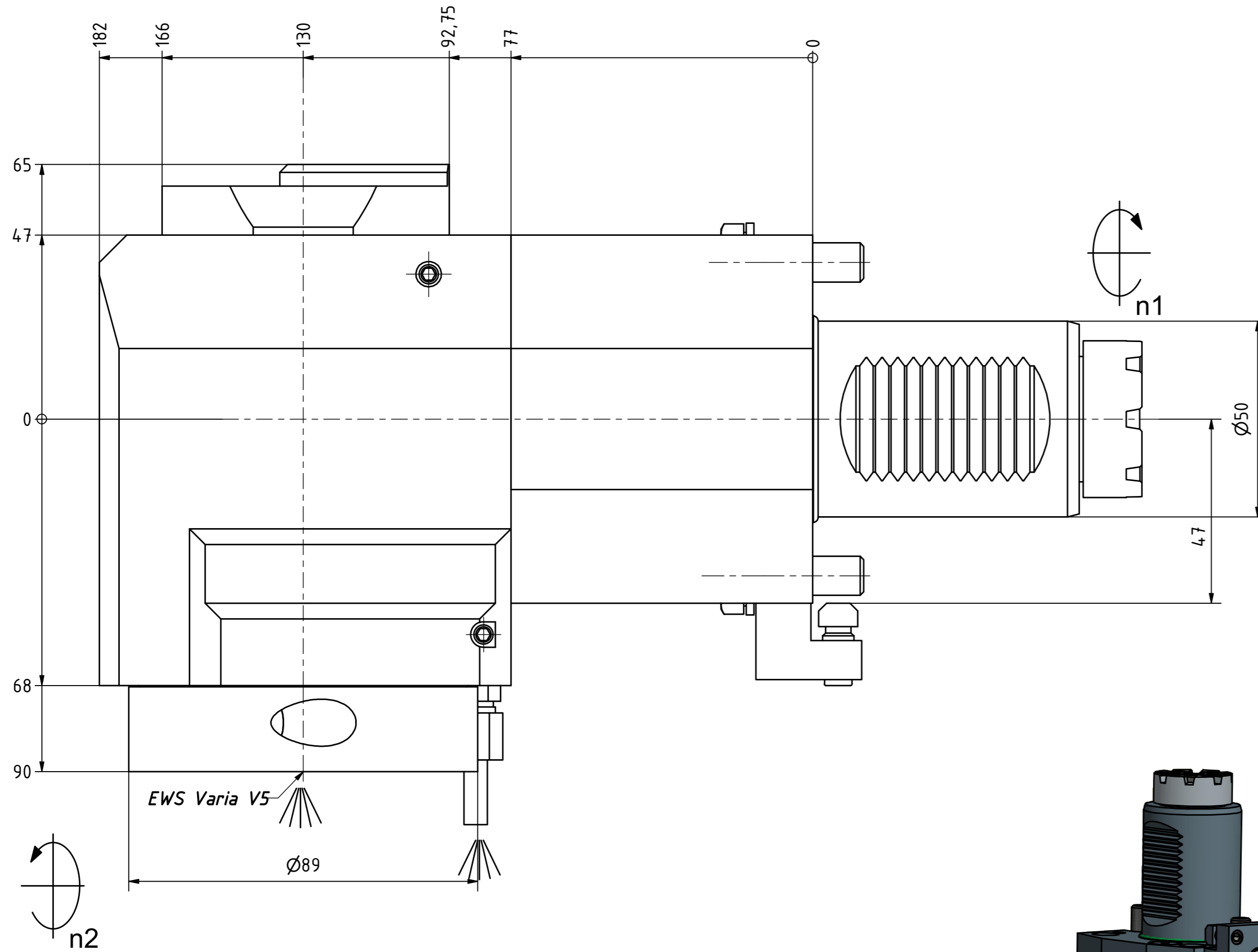
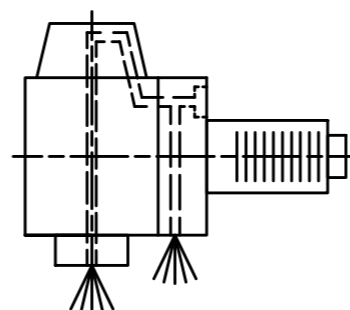

Innen- und Aussenkuehlung / Inside and outside coolant supply
 Kuehlmittelfiltrierung-50µ / coolant filtration-50µ

Copyright **EWS Tool Technologies**
 Weitergabe und Vervielfaeltigung dieser Unterlage,
 Verwertung und Mitteilung ihres Inhalts nicht
 gestattet, soweit nicht ausdrecklich zugestanden.
 Zuwiderhandlungen verpflichten zu Schadenersatz.

Bemerkung - Note Für Trockenlauf geeignet! Use without coolant fluid allowed!	Technische Daten - technical data Weight = 12.270 [kg] Torque max. (M1/M2) = 100 / 100 [Nm] Speed max. (n1/n2) = 4000 / 4000 [1/min] Gear ratio (i)=n1/n2 = 1:1 Pressure (pmax) = 70 [bar]	Benennung - Title Radial Bohr und Fräskopf Radial drilling and milling head	 EWS Weigle GmbH & Co. KG Maybachstr. 1 D-73066 Uhlingen www.ews-tools.de Technische Aenderungen vorbehalten! Subject to technical modifications! IDENT: D-EWS-006488 Nr. - No. 60.50V5TOEMRLIKDX130 MNR. 133489	 REV: -/-
---	---	---	---	--