

Doppelverzahnung Lizenz Traub
double tooth system licence Traub

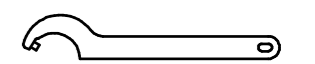
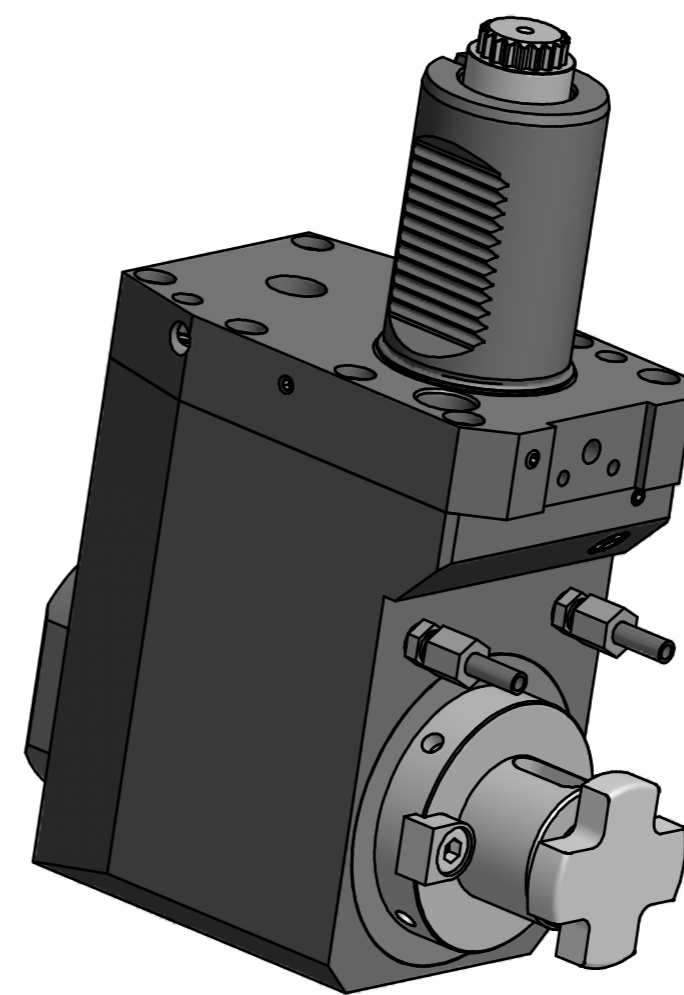
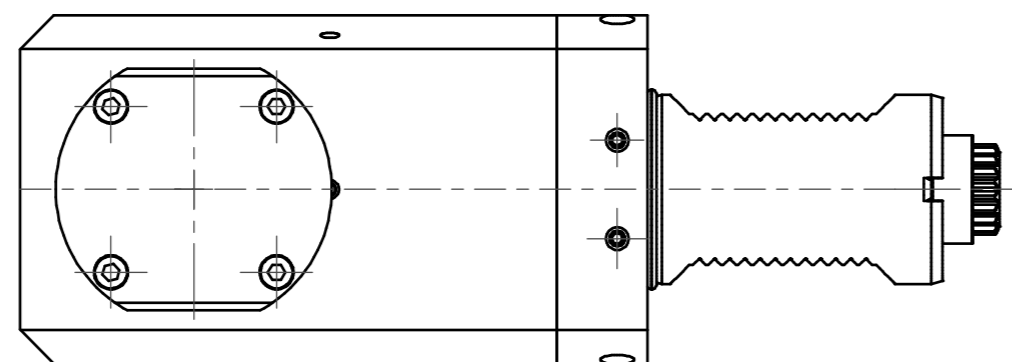

Hakenschlüssel
mit Zapfen
Hook wrench
with fixed pin
DIN1810 B 68x75

Copyright **EWS Tool Technologies**
Weitergabe und Vervielfältigung dieser Unterlage,
Verwertung und Mitteilung ihres Inhalts nicht
gestattet, soweit nicht ausdrücklich zugestanden.
Zuwendungen verpflichten zu Schadenersatz.

Bemerkung - Note mit Kegelrollenlager with taper roller bearing(s)	Technische Daten - technical data M ₁ / M ₂ = 40 / 120 Nm n ₁ / n ₂ = 6000 / 2000 1/min i (N ₁ :N ₂) = 2,878:1	Benennung - Title Radial Fräskopf. zurückgesetzt Radial milling head offset	name	date	Technische Änderungen vorbehalten! Subject to technical modifications!	DIN A2
			drawing	12.03.2007		
			Nr. 82.5040KR5480RLI3-BG40X120		File: 82.50405480RLI3-BG40X120_OUT.idw Blatt - page 1 (1)	