

Spannzange / collet ER40 DIN6499  
Spannbereich / clamping range: 3,0 - 26,0

Gewindebohrzange / tapping collet  
ET-1-40 M6-M16

Doppelverzahnung Lizenz Traub  
double tooth system licence Traub

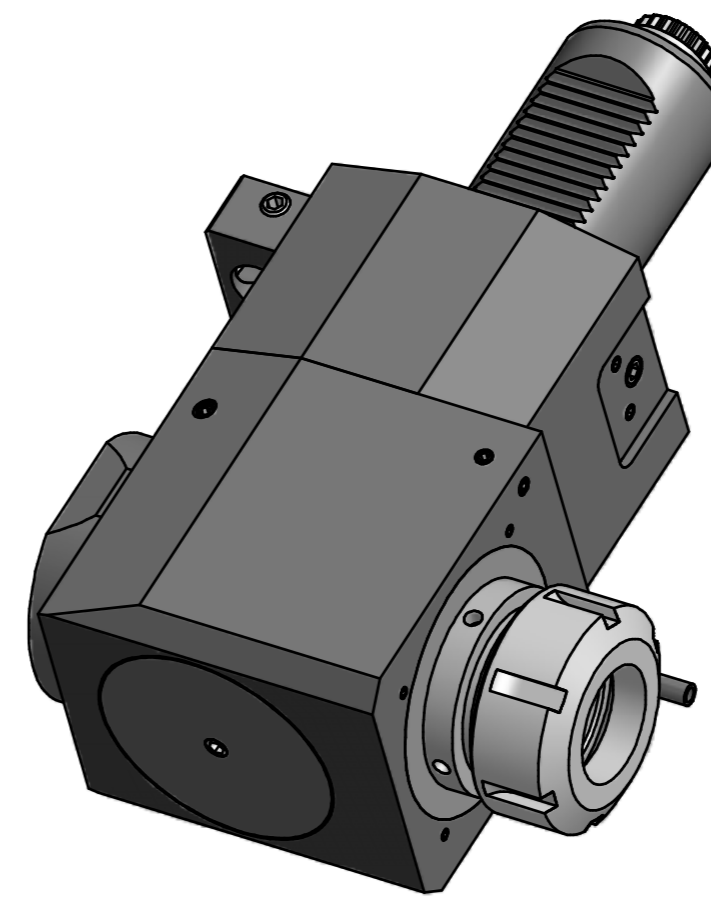
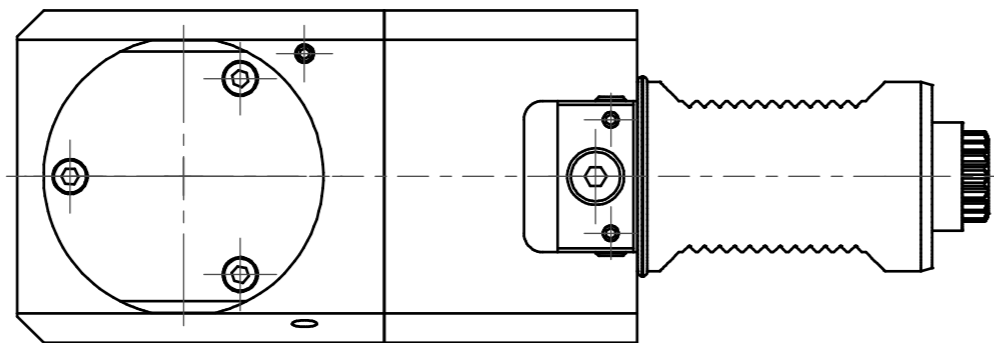

Copyright **EWS Tool Technologies**  
Weitergabe und Vervielfältigung dieser Unterlage,  
Verwertung und Mitteilung ihres Inhalts nicht  
gestattet, soweit nicht ausdrücklich zugestanden.  
Zuwendungen verpflichten zu Schadenersatz.

Benennung - Title	Technische Daten - technical data		Benennung - Title	name	date	Technische Änderungen vorbehalten! Subject to technical modifications!
	M <sub>1</sub> / M <sub>2</sub> = 100 / 100 Nm n <sub>1</sub> / n <sub>2</sub> = 4000 / 4000 1/min i (N <sub>1</sub> :N <sub>2</sub> ) = 1:1					
Radial Bohr und Fräskopf Radial drilling and milling head			EWS Weigete GmbH & Co. KG Maybachstr. 1 D-73066 Ulm/lingen Tel. +49(0)7161/93040-10		DIN A2 File: 60.50405480RLGLX120_OUT.idw Blatt - page 1 (1)	