

EWS-Varia V5

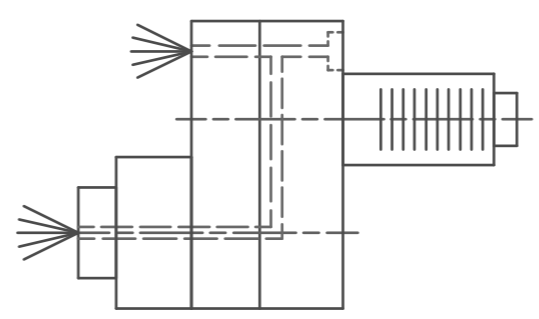
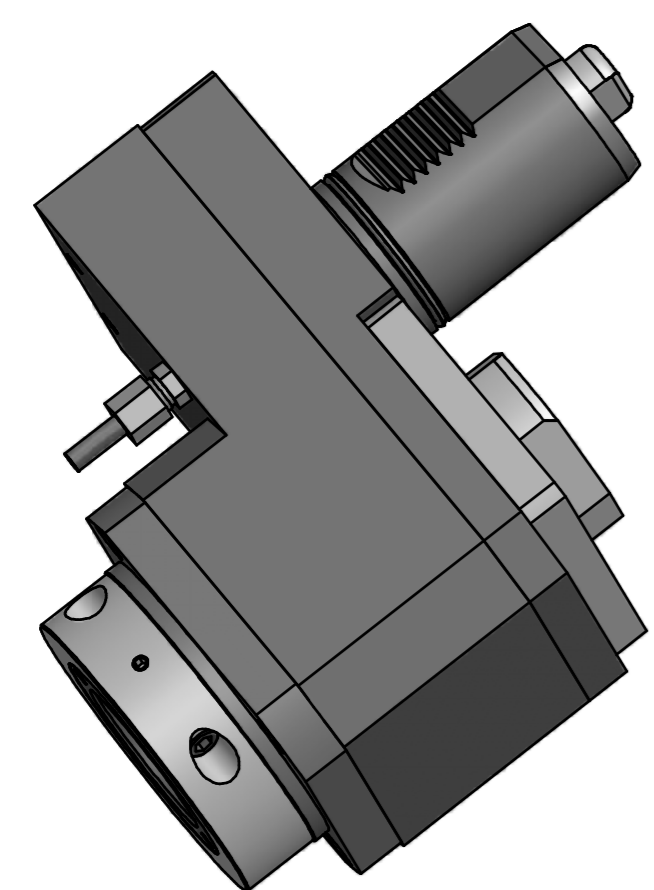

Innen- und Aussenkuehlung  
Inside and outside coolant supply

Copyright **EWS Tool Technologies**  
Weitergabe und Vervielfaeltigung dieser Unterlage,  
Verwertung und Mitteilung ihres Inhalts nicht  
gestattet, soweit nicht ausdrecklich zugestanden.  
Zuwaerhandlungen verpflichten zu Schadenersatz.

Bemerkung - Note Nicht ohne Kuehlmittel betreiben! Not for use without coolant-fluid!	Technische Daten - Technical data M1 / M2 = 100 / 100 Nm n1 / n2 = 4000 / 4000 1/min i (N1:N2) = 1:1 Pmax = 70 bar	Benennung - Title <b>Axial Bohr u. Fräskopf achsversetzt</b> <b>Ax. drill. and mill. head offset</b>	name Schmid	date 08.03.2007	Technische Aenderungen vorbehalten! Subject to technical modifications! Nr. <b>50.50V5MP630RIK</b> File: 50.50V5MP630IK_OUT.idw	DIN A2
			EWS Weigle GmbH & Co. KG Maybachstr. 1 D-70066 Uhlingen Tel. +49(0)7161/93040-10			